



IFS-2600

Fire Indicator Panel

OPERATORS MANUAL

Installation Precautions

Adherence to the following will aid in problem-free installation with long-term reliability:

WARNING - Several different sources of power can be connected to the fire alarm control panel. Disconnect all sources of power before servicing. Control unit and associated equipment may be damaged by removing and/or inserting cards, modules, or interconnecting cables while the unit is energized. Do not attempt to install, service, or operate this unit until manuals are read and understood.

Verify that wire sizes are adequate for all initiating and indicating device loops. Most devices cannot tolerate more than a 10% I.R. drop from the specified device voltage.

Like all solid state electronic devices, this system may operate erratically or can be damaged when subjected to lightning induced transients. Although no system is completely immune from lightning transients and interference, proper grounding will reduce susceptibility. Overhead or outside aerial wiring is not recommended, due to an increased susceptibility to nearby lightning strikes. Consult with the Technical Services Department if any problems are anticipated or encountered.

Disconnect AC power and batteries prior to removing or inserting circuit boards. Failure to do so can damage circuits.

Remove all electronic assemblies prior to any drilling, filing, reaming, or punching of the

enclosure. When possible, make all cable entries from the sides or rear. Before making modifications, verify that they will not interfere with battery, transformer, or printed circuit board location.

Do not overtighten screw terminals. Overtightening may damage threads, resulting in reduced terminal contact pressure and difficulty with screw terminal removal.

This system contains static-sensitive components. Always ground yourself with a proper wrist strap before handling any circuits so that static charges are removed from the body. Use static suppressive packaging to protect electronic assemblies removed from the unit.

Follow the instructions in the installation, operating, and programming manuals. These instructions must be followed to avoid damage to the control panel and associated equipment. FACP operation and reliability depend upon proper installation.

This equipment must be correctly programmed and installed to suit the specific application. Please ensure correct operational parameters are set prior to commissioning. If further details on programming options are required, please consult the programming manual or contact our helpful technical support personnel.

EMC WARNING:

This equipment may radiate radio frequency energy. It may also be affected by radio frequency energy and, if not installed and operated in accordance with the manufacturers instructions, may cause interference to radio communications. It has been tested and found to comply with the Class A radiated and conducted EMI requirements of AS/NZ 3548:1995 (including Amendments 1 & 2) as well as the EMI susceptibility requirements of Clause C3.5 in AS4428.0:1997.

Radio communication devices should not be used in the vicinity of fire panels or associated ancillary devices and systems.

Documentation Feedback

Your feedback helps us keep our documentation up to date and accurate. If you have any comments or suggestions about our printed manuals you can email us.

Please include the following information:

- Product name and version number (if applicable)
- Manual part number and revision (found on the front cover)
- Page number
- Brief description of the content you think should be improved or corrected
- Your suggestion for how to correct/improve documentation

Send email messages to:

techpubs@notifier.com.au

Please note this email address is for documentation feedback only. If you have any technical issues, please contact your nearest branch for technical support.

Table of Contents

- Section 1 About this Manual 2**
 - 1.1. Notes, Cautions and Warnings.....2
 - 1.2. Related Documentation.....2
- Section 2 System Overview..... 3**
 - 2.1. Overview3
 - 2.2. Features3
 - 2.3. System Description4
 - 2.4. Internal Buzzer.....5
 - 2.5. LCD Display5
 - 2.6. Keypad6
- Section 3 Operation 7**
 - 3.1. Initial Checklist7
 - 3.2. Power Up Checklist7
 - 3.3. Functional Tests8
 - 3.4. Fault Record.....9
 - 3.5. Indicators..... 10
 - 3.6. Suggested Alarm Procedure..... 11
 - 3.7. Fire Fighter Functions 11
 - 3.8. Global Operator Functions..... 13
 - 3.9. Zone Operator Function 16
 - 3.10. Standard Outputs..... 20
 - 3.11. Relay Expansion Boards 21
 - 3.12. Printer Output..... 21
 - 3.13. IFS-2600 Block Diagram 22

Section 1 About this Manual

1.1. Notes, Cautions and Warnings

This manual contains notes, cautions and warnings to alert the reader as follows:



NOTE: Supplement information for a topic such as tips and references.



CAUTION: Information about procedures that could cause programming errors, runtime errors, or equipment damage.



WARNING: Indicates information about procedures that could cause irreversible equipment damage, irreversible loss of programming data or personal injury.

1.2. Related Documentation

Related documentation:

Title	Document Number
Technical & Programming Manual	10069
AUSTRALIAN STANDARD FOR Automatic Fire Detection And Alarm Systems Control And Indicating Equipment.	AS-4428.1
AUSTRALIAN STANDARD FOR Automatic Fire Detection And Alarm Systems. System Design Installation And Commissioning.	AS-1670
AUSTRALIAN STANDARD FOR SAA Mechanical Ventilation And Air Conditioning Fire Precautions In Buildings With Air-handling Systems.	AS-1668.1

Table 1-1 Related Documentation

Section 2 System Overview

2.1. Overview

The overall intent of a fire protection system is to provide warning should smoke or a fire be detected. The systems can be configured to alert occupants of the building, advise fire brigades and take necessary action to either extinguish the fire and/or stop the fire from spreading. The fire indicator panel is an essential part of a buildings fire protection systems, it must therefore be properly and carefully installed, configured and maintained.

2.2. Features

The IFS-2600 Fire Indicator Panel (FIP) is designed to provide simplicity to the end user. It uses complex microprocessor technology to make the end-users task easier. In the event of a fire, simple precise instructions are required, thus making the tasks of the fire fighter easier.

Together with the microprocessor, there are custom designed components and circuitry ensuring greater reliability and suppression from external sources.

The FIP uses both a liquid crystal display and conventional LED displays for fast and accurate display of system status and changing events.

A custom designed membrane keypad is used together with the liquid crystal display and LED indicators to provide fast, efficient and simple modes of operation. The keypad also provides the required flexibility for the programming of the many user configurable options of this FIP. The FIP can be configured on-site without the need of expensive programmers or components. These configured options are retained by the FIP even if the power is totally disconnected.

A serial printer can also be connected if required. The printer can be used to output programming information for ease of modification, for safekeeping and to assist in the commissioning of the installation.

Most outputs considered as optional by other manufacturers are provided as standard with the IFS-2600. The IFS-2600 uses serial chain mimic outputs which significantly saves time and costs of cabling to mimic panels.

A door holder power supply (using optional transformer) is incorporated into the system for the release of smoke and fire doors on alarm.

IFS-2600 is available in a standard 8-zone configuration and can be upwards expandable to its fully expanded state as required. IFS-2600 in its fully expanded state can;

- Monitor 64 detection zones
- Control 64 optional "mapped" relay outputs
- Output to a serial printer
- Output serially to a mimic panel
- Control up to 30 door holders
- Interface as required to any Australian Fire Brigade

IFS-2600 has been designed to be functional, flexible and reliable whilst maintaining a user-friendly environment.

2.3. System Description

The basic IFS-2600 FIP consists of

Quantity	Description
1	Wall Mounting Cabinet with Manual Call Point
1	Main Control Board (Located on inside of inner door)
1	Main Termination Board (Located in rear of panel enclosure)
1	Mains Transformer
1	Power Supply PCB fitted to Main Termination Board

Optional equipment that may be found fitted to the IFS-2600

Maximum Quantity	Description
2	Batteries 12V
7	Zone Expansion Board (8 Zone)
4	Display Expansion Board (16 Zone)
8	Relay Expansion Board
1	Door Holder Power Supply Transformer

IFS-2600 requires the basic equipment as listed above to function. The microprocessor and other sensitive electronic components are located on the Main Processor Board, located on the inner panel that can be easily removed during installation to allow improved terminal access.

Power supplies and I/O's are located on the Main Termination Board. Terminated to this board, at a minimum, should be the transformer, batteries, bell and at least one AZF circuit.

With the cabinet outer door closed, the viewing window allows a clear view of the keypad, LCD and LED's.

2.4. Internal Buzzer

A buzzer is located on the main termination board to provide an audible alert to persons in the near vicinity of the FIP of a fault or a zone has gone into alarm. This buzzer can be silence by hitting any key on the keypad.

The buzzer is also used for "audio-feedback" during keypad operation; one short beep as a key is depressed verifies the key operation.

One long beep (approx 1 second) indicates that an incorrect entry has been made.

Two consecutive short beeps verify entry into a different mode, i.e. "ALARM TEST MODE", "ISOLATE MODE" etc.

2.5. LCD Display

In addition to the LED's a 16-character x 2-line liquid crystal display is provided to indicate system status and changing events and programming information. Any keystroke or event will actuate the backlighting on the display for better readability in dark areas. The backlighting will automatically turn off in 30 seconds if no further keys are pressed.

The primary task of the LCD is for programming and subsequent configuration of the fire indicator panel. The LCD is also used to indicate the current mode of operation, eg "ISOLATE MODE", "ALARM TEST MODE" etc. The LCD is also used as a prompt for user entries eg "ENTER ZONE #".

When the panel is in the normal mode of operation, the LCD displays and constantly updates the current zone status including the total number of;

- Zones In Alarm
- Zones In Fault
- Zones Isolated

2.6. Keypad

The custom-designed 30 key membrane keypad is the users interface to accessing all zone and global functions of the IFS-2600. These 30 keys consist of;

- Five Specialised single-stroke Fire Fighters Keys
- Five Global function keys
- Four Programming Keys
- Four Zone function keys
- Twelve Keys for numeric entry



Figure 2-1

Operations and functions of these keys are explained in the following chapter.

Section 3 Operation

3.1. Initial Checklist

Suitably qualified technicians must install the panel. The following check procedures are recommended after every installation and prior to initial power-up.

A thorough visual inspection should be made to every aspect of the fire panel. This includes loose wire, metal filings, loose circuit boards, loose cabling, damage in transit etc.

All problems must be rectified immediately as they could cause incorrect operation or permanent damage to the equipment.

- System general appearance good
- Cabinet colour and condition good
- Cabinet keyed 003
- All circuit boards firmly fastened
- Manual call point fitted & functional
- Viewing window clear and firmly secured
- Cable entries adequately sealed
- 240VAC mains cabling is correctly terminated
- All earthing secured
- Transformer securely mounted
- Transformer correctly wired
- All ribbon cables firmly secured
- All operational zones adequately identified
- All fuses correct value and fitted properly
- All other modules securely fitted
- Manufacturing label affixed

You are now ready to power up the IFS-2600 Fire Indicator Panel.

3.2. Power Up Checklist

- Ensure batteries are disconnected
- Turn mains switch to "on"
- The "mains on" led should light
- Allow 15 seconds for the panel to perform its start up tests
- Connect batteries

3.3. Functional Tests

- Primary ac supply voltage: 200 or 220 or 240vac $\pm 10\%$ as required
- Charger output voltage without batteries: 27.3v dc
- Keypad functional
- Perform auto test

- Led's all functional
- LCD backlighting functional
- Liquid crystal display functional
- Zone fault detection
- Zone alarm detection

- Internal sounder operating
- MCP loop wired to zone number _____ (if applicable)
- Test auxiliary power output
- Test bell output
- Test warning system output
- Test ACF output
- Test door holder output (optional)
- Test bell output supervision
- Test warning system output supervision
- Test ACF output supervision
- Test brigade alarm relay #1
- Test brigade alarm relay #2
- Test standby relay (normally energised)
- Test fault relay (normally energised)
- Test mains fail relay
- Test isolate relay
- Test general alarm relays (2)
- Test relay boards (if fitted)
- Test open collector output boards (if fitted)
- Press "battery test" once
- If batteries are flat, allow 24hrs to charge and then re-test

3.4. Fault Record

FAULT	CORRECTION	DATE

TESTS SATISFACTORILY COMPLETED.

TESTED BY _____

SIGNATURE _____

DATE OF TEST _____

If all faults have been rectified and all tests are completed satisfactorily, the **2600** fire indicator panel is now ready for operation.

3.5. Indicators

Qty	Descriptor	Colour	Function	Buzzer
1	MAINS ON	Green	Illuminates when there is 200/220/240 VAC supply to the panel.	
1	BATTERY FAULT	Yellow	Illuminates if the battery fails a battery test. Illuminates if batteries are disconnected >30 seconds. Illuminates if batteries are short circuit >30 seconds.	Yes
1	PSU FAULT	Yellow	Illuminates if the power supply is outside the manufacturers range.	Yes
1	CHARGER LOW	Yellow	Illuminates if the battery charger is outside the recommended float charge voltage.	Yes
1	COMMON FAULT	Yellow	Illuminates if; Any un-isolated zone goes into fault. ACF output is open or short circuit Bell output is open or short circuit Warning System output is open or short circuit Power Supply Fault including Battery or Charger MAF Isolate Input is Open Circuit Configuration Fault	Yes
1	ACF ACT	Red	Illuminates if the ACF output has been activated.	
1	ACF FLT	Yellow	Illuminates if the ancillary circuit is open or short circuit. The LED will extinguish when the load is restored.	Yes
1	ACF ISO	Yellow	Illuminates if the ancillary output has been manually isolated.	
1	Bell ACT	Red	Illuminates when the bell output has been energised.	
1	Bell FLT	Yellow	Illuminates if the bell circuit is open or short circuit. The LED will extinguish when the load is restored.	Yes
1	Bell ISO	Yellow	Illuminates if the bell output has been manually isolated.	
1	Warning System ACT	Red	Illuminates if the Warning System output has been energised.	
1	Warning System FLT	Yellow	Illuminates if the Warning System circuit is open or short circuit. The LED will extinguish if the load is restored.	Yes
1	Warning System ISO	Yellow	Illuminates if the Warning System has been manually isolated.	
8	ALARM LEDS	Red	This LED will flash if it's corresponding zone goes into alarm. It will remain flashing until it is Acknowledged at which time it will go steady and remain on until the alarm is reset. If the zone is programmed as a time delay type, a steady LED indicates the "pre-alarm" condition. If the zone is isolated and in alarm it will also be steady.	Yes
8	FAULT LEDS	Yellow	This LED illuminates if it's corresponding zone goes into fault. It will remain on until the fault is removed.	Yes
8	ISOLATE LEDS	Yellow	This LED illuminates if its corresponding zone is isolated. It will remain on until the zone is de-isolated.	

3.6. Suggested Alarm Procedure

The following is a suggested alarm procedure for use by building fire officers or duty wardens. The fire indicator panel is designed for use by qualified fire fighters and it is strongly recommended that the fire panel not be operated in an emergency situation by anyone other than suitably qualified fire fighters.

- Do not open fire indicator panel door or press any buttons until fire officers arrives.
- Determine location of the fire by inspecting the label beside any lit red zone alarm LEDs on the panel.
- Visually inspect area at a safe distance for actual fire or false alarm.
- Notify fire-monitoring station of either result.
- Perform evacuation and extinguishing operations as required.
- IF a FIRE, direct fire fighters to the fire indicator panel and cause of alarm as they arrive.
- IF a FALSE ALARM, advise maintenance technicians to determine and rectify cause.
- Record all events in logbook.



NOTE: A suitably qualified fire officer should perform the above procedure. These are suggested procedures only, and if specific fire procedures are available or issued, they **MUST** prevail.

3.7. Fire Fighter Functions

Fire Fighter Functions are those specifically used by the Fire Brigade on attendance. Following is an explanation of their operation and the keystrokes required to perform the function required. These keys are located at the top of the keypad marked FIREFIGHTER'S FACILITY and bordered in red.

ACKNOWLEDGE

ACK

The purpose of the internal buzzer is to alert persons of a new event on the panel, and a new potential fire danger. Once the fire's location has been determined, the fire-fighter may wish to silence the internal buzzer without having to totally reset the alarm.

When the buzzer is operating, pressing the "ACK" key once will silence it, however the External Alarm Bell will continue to sound. If a subsequent alarm arises, the buzzer will be reactivated and a second ACK operation will be required to silence it.

When an alarm is acknowledged, the Alarm LED will stop flashing and light continuously.

RESET**RESET**

The reset function momentarily disconnects power, and resets all alarm parameters for the zone(s) that have been acknowledged. This returns the zone back to its "normal" state. The reset key only operates on zones with acknowledged alarms.

ISOLATE**ISOLATE**

The isolate function prevents the transmission of alarms or faults from the zones to the master alarm facility. The isolate key only operates on zones with acknowledged alarms.

BELL ISOLATE**EXT BELL
ISOL**

Depressing the "EXT BELL ISOLATE" key will isolate the bells. The "Ext Bells Isolate" LED will illuminate and the bells will not sound until the bells are de-isolated. Pressing "EXT BELL ISOLATE" a second time will de-isolate the bell.

WARN SYS ISOLATE**WARN SYS
ISOL**

Depressing the "WARN SYS ISOLATE" key will isolate the warning system. The "Warn Sys Isolate" LED will illuminate and the warning system will not operate in the event of an alarm. Pressing "WARN SYS ISOLATE" a second time will de-isolate the warning system.

3.8. Global Operator Functions

Global functions are those relating to the overall system and are not specific to particular zones. Following is an explanation of their operation and the keystrokes required to perform the function.

BATTERY TEST



This function tests the performance of the batteries fitted to the system. Pressing this button will initiate a battery test as specified in AS4428. The test will temporarily disconnect the batteries from the panel and apply load on the batteries for 15 seconds.

The result of the test will be displayed on the LED's. If the "Battery Fault" LED is on, only a successful battery test will turn the LED off. The pressing of any key during the test period will abort the battery test and return the system back to normal mode.

Battery test function is disabled when the panel is in alarm condition.

AUTO TEST MODE



This function will perform a fixed automatic test procedure to the panel. This mode cannot be selected if any zone(s) is in alarm. Auto test will perform the following test functions;

1. Turn on ALL LEDs for 0.5 seconds
2. Test LCD backlighting
3. Test panel memory (E²ROM & RAM)
4. Test LCD
5. Isolate all alarm zones
6. Fault test all alarm zones
7. Alarm test all alarm zones
8. Test buzzer

The pressing of any key during "AUTO TEST" will abort the tests and return the system back to normal mode once the current test is complete.



NOTE: During "AUTO TEST", all zones are treated as zone type #1 (standard latching type with 2 second delay). Once AUTO TEST has finished, all zones will be reset and returned back to their previously configured types.

WALK TEST MODE



This function will place the panel into "walk test" mode. Walk test mode is used for the on-site testing of detector zones. This mode cannot be selected if any zone(s) is in alarm. Entry to walk test mode will be acknowledged by three beeps and the LCD will display "WALK TEST MODE".

For the duration of walk test mode, all zones are changed to output configuration #2 (indicate and ring bells only) and all zones are set to type #1 (standard latching, 2 second).

If the bells are not required to ring during walk test, simply press the "EXT BELL ISOLATE" key once. The EXT BELL ISOLATE LED will illuminate to verify that the bells have been isolated.

Any alarm signal from detectors etc. will be received by the panel on its appropriate zone. The panel will beep to acknowledge receipt of the alarm and indicate the alarm by illuminating the appropriate alarm LED for 4 seconds (the bells will also ring for a 3 second period unless previously isolated).

The zone and detector will then be automatically reset for 15 seconds

If the optional printer is connected, the alarm will be printed out as it is received. This can eliminate the need for a second serviceman to record zone numbers during walk test and the printout can be retained for verification at a later date.

Pressing any key will terminate the walk test mode and return the panel back to normal operation, restoring all zone types and output configurations also ensuring that bell and ancillary outputs are de-isolated. The bells will give three pulses of 1 second each to warn any testers still in the building that walk test mode has been terminated.

Failure to receive any alarms or keystrokes within a 15 minutes period will result in the panel automatically exiting walk test mode and returning back to normal as follows:

1. Bell outputs to be de-isolated.
2. Ancillary outputs to be de-isolated.
3. Bell will sound 3 times, each of 1-second duration.
4. Exit from walk test mode.
5. Zone types and output configurations restored

ACF ISOLATE



Depressing the "ACF ISOLATE" key will isolate the ACF (Ancillary output) and the Door Holder Output. The ACF isolated LED will illuminate and the output will not operate until de-isolated. Pressing "ACF ISOLATE" for a second time will de-isolate the output.

If the ancillary output has already been tripped and is programmed as latching, isolating the ACF will not affect the existing ancillary output. If the ACF is isolated prior to the alarm, it will prevent the ancillary output from tripping. This does not apply to the Door Holder output.

ACF RESET



Resetting of the ancillary output (ACF) is only required if the ancillary output was programmed as latching.

The ancillary alarm will remain latched until manually reset. Pressing the "ACF RESET" button will extinguish the 'ACF Activated' LED and de-energise the ancillary output. Pressing "ACF RESET" when the ACF is not tripped will have no effect.

3.9. Zone Operator Function

Zone functions are those relating specifically to the detection zones. Following is an explanation of their operation and the keystrokes required to perform the function required.

ALARM TEST

ALARM TEST

#

ENT

The alarm test function momentarily disconnects the detector lines of the zone(s) under test and simulates a detector going into alarm, therefore testing the zone(s) alarm detection capability.

A resistive load equal to worst case alarm condition is placed on the zone for a period of 120 seconds and then removed, if the zone being tested is not a latching type, the alarm will reset automatically once the load is removed. Acknowledging and resetting the alarm will terminate an alarm test.

Once the zone has alarmed, all outputs are initiated (as programmed) similar to a real alarm.

The zone may be isolated prior to an alarm test if desired; this will prevent any outputs from operating.

'#' in the above key sequence is the zone number.

If only one zone is to be tested, use the appropriate number. Alternatively the "ALL" button can be used to simultaneously test all zones.

To perform an alarm test:

1. Press the "ALARM TEST" button once; the buzzer will give 2 short beeps to indicate that alarm test mode has been entered.
2. The LCD display will read "ALARM TEST MODE, ENTER ZONE No.".
3. Now enter the zone number ("##") 1-64 or "all"
4. Press "ENT"

If a correct entry is made, alarm testing on the zone commences immediately. However remember there is a 2 second transient delay on all zones. It will therefore take approximately 2 seconds before the zone registers an alarm (this could be longer, depending on zone type).

A long beep will signify an incorrect entry and will revert back to normal operating mode. The "ALARM TEST" button will need to be depressed again to re-enter alarm test mode.

FAULT TEST

FAULT TEST**#****ENTER**

The fault test function momentarily disconnects the detection zone(s) under test and simulates the worst-case condition for fault.

A resistor load equal to worst case fault is placed on the zone continuously for 5 seconds then the zone is returned back to its normal condition.

If several zones are being tested consecutively and are being entered at a rate faster than the 5-second fault timer, the fault timeout will occur 5 seconds after the last entry was completed.

Once the zone has registered a fault, all outputs relating to that zone are initiated similar to a real fault.

The zone may be isolated prior to a fault test if desired. This will prevent any outputs from operating.

'#' in the above key sequence is the zone number.

If only one zone is to be tested, use the appropriate zone number. Alternatively the "ALL" button can be used to simultaneously test all zones.

To perform a fault test on a particular zone or on all zones:

1. Press the "FAULT TEST" button once. The buzzer will give 2 short beeps to indicate that fault test mode has been entered.
2. The LCD display will read "FAULT TEST MODE, ENTER ZONE No."
3. Enter the zone number ("#") 1-64 or "all".
4. Press "ENTER".

A long beep will signify an incorrect entry and the panel will revert back to normal operating mode. The "FAULT TEST" button will need to be pressed again to re-enter fault test mode.

If a correct entry is made, fault testing on the zone commences and the fault LED will illuminate.

ISOLATE

ISOLATE**#****ENTER**

The isolate function prevents the transmission of alarms or faults from the zones, to the master alarm facility.

'#' in the above key sequence is the zone number.

If only one zone is to be isolated, use the appropriate zone number. Alternatively the "ALL" button can be used to simultaneously isolate all zones.

To isolate a particular zone or all zones:

1. Press the "ISOLATE" button. The buzzer will give 2 short beeps to indicate that isolate mode has been entered.
2. The LCD display will read "ALARM ISOL. MODE, ENTER ZONE No.".
3. Enter the zone number ("#") 1-64 or "all".
4. Press "ENTER".

A long beep will signify an incorrect entry and will revert back to normal operating mode. The "ISOLATE" button will need to be depressed again to re-enter isolate mode.

If a correct entry is made, the zone is immediately isolated. If the zone is already in alarm, all of its alarm outputs are isolated and indicators remain visible.

If the "ALL" function is performed, all zones will be isolated, regardless of their previous state. Performing the "ALL" function for a second time will de-isolate all zones.

RESET

RESET**#****ENTER**

The reset function momentarily disconnects power, and resets all alarm parameters for the zone(s) being reset. This returns the zone back to its "normal" state.

'#' in the above key sequence is the zone number.

If only one zone is to be reset, type in the zone number. Alternatively the "ALL" button can be used to simultaneously reset all zones.

To perform a reset on a particular zone or on all zones:

1. Press the "RESET" button. The buzzer will give 2 short beeps to indicate that reset mode has been entered.
2. The LCD display will read "ALARM RESET MODE, ENTER ZONE NO".
3. Enter the zone number ("#") 1-64 or "all".
4. Press "ENTER".

A long beep will signify an incorrect entry and will revert back to normal operating mode. The "RESET" button will need to be depressed again to re-enter reset mode.

If a correct entry is made, resetting of the zone begins immediately. Any alarm indication will be removed immediately; also resetting the zone(s) programmed outputs.

3.10. Standard Outputs

Output	Type	Description
Standby ①	Change over relay contact	Normally energised relay: Will de- energise if system volts fall below 21V. This usually means AC has failed and batteries are getting low. i.e. panel is about to shut down.
Brigade Alarm #1	Change over relay contact	Normally de-energised relay: Will energise if requested by the zone output configuration of the non- isolated zone(s) in alarm.
Brigade Alarm #2	Change over relay contact	Normally de-energised relay: Will energise if requested by the zone output configuration of the non- isolated zone(s) in alarm.
Fault①	Change over relay contact	Normally energised relay: Will de-energise if a common fault is registered.
Mains Fail (NV)①	Change over relay contact	Normally energised relay: Will de-energise if the AC fails
Isolate	Change over relay contact	Normally de-energised relay: Will energise if any zones are isolated. general alarm normally de-energised relay (2 off). Will energise if requested by the zone output configuration of the non-isolated zone(s) in alarm.
General Alarm 1	Change over relay contacts	Normally de-energised relay (2 off): Will energise if requested by the zone output configuration of the non-isolated zone(s) in alarm.
General Alarm 2	Change over relay contacts	Normally de-energised 24VDC: Output will energise if requested by the zone output configuration of the non-isolated zone(s) in alarm. Will remain energised until alarm is reset or bells are isolated. Monitored.
Bell②	24 VDC Output 1A Fused	Normally de-energised 24VDC: Output will energise if requested by the zone output configuration of the non-isolated zone(s) in alarm. Will remain energised until alarm is reset or warning system is isolated. Monitored.
Warning System②	24 VDC Output 1A Fused	Normally De-energised 24VDC: Output, will energise if requested by the zone output configuration of the non- isolated zone(s) in alarm. Monitored.
Ancillary (ACF)②	24 VDC Output 1A Fused	If ancillary is set as non-latch: Ancillary will remain energised until alarm(s) is reset. If ancillary is set as latching: Ancillary will remain energised until ancillary is manually reset from the keypad. Even if the zone has been reset.
Door Holder	24 VDC Output up to three amps	Normally energised 24VDC output: Will de-energise on general alarm. NOTE: This output is isolated through the ACF Isolate Function. 24VDC power is supplied via a second transformer. This transformer is not battery backed, therefore on AC fail this output will automatically de-energise.
Auxiliary Power	24 VDC Continuous	Power output for use with ancillaries (500mA maximum).
Mimic Outputs	Serial four wire mimic outputs	<p>A mimic output is standard on all IFS-2600 panels. This output mimics the status of all alarm zones fitted on the panel to a remote mimic panel in the building.</p> <p>The four (4) wire serial mimic decoder board can be connected to the panel by using a 4-core cable. 4 conductors are used, 24VDC, 0V, data, & clock connecting directly to their respective terminals at the panel and the mimic.</p> <p>The decoder boards contain up to 64 alarm LED indicators, 64 fault LED indicators, a sounder, sounder mute, lamp test facility and conventional mimic outputs at the rear of the board for interfacing to conventional mimic panels or driving auxiliary relay outputs up to a maximum of 20mA.</p> <p>NOTE: Firmware must be Version 6 or above for mimic operation.</p>



- NOTE:**
- ① Normally energised (fail safe) relay
 - ② Monitored circuit, EOL resistor or load is required.

3.11. Relay Expansion Boards

The maximum number of boards that can be fitted is eight (i.e.: 64 relays). Each board contains 8 change-over relay outputs. Relays can be programmed to simulate:

- Brigade Alarm Relay #1
- Brigade Alarm Relay #2
- Fault Relay
- Mains Fail Relay
- Isolate Relay
- General Alarm Relays
- Bell Output
- Ancillary Output
- Door Holder Output
- Door Switch
- Reset

or can be used to

- | | |
|-----------------|-----------------------------------|
| • “AND MAP” | Up to 5 zones in Alarm |
| • “OR MAP” | Up to 5 zones in Alarm |
| • “MAP FAULT” | Up to 5 zones in Fault |
| • “MAP ISOLATE” | Up to 5 zones in Isolate |
| • “MAP ISO/FLT” | Up to 5 zones in Fault OR Isolate |

3.12. Printer Output

Located on the main termination board, a portable serial printer may be connected to the DB9 serial port provided.

Most standard IBM compatible serial printers are suitable for this operation; refer to technical/programming manual for printer port characteristics to ensure suitability and correct operation.

If a portable printer is to be used, it must be specifically modified to operate from the IFS-2600 if the printer is to be powered via the DB9 socket on the panel. The printer uses hardware handshaking and will be enabled automatically.

3.13. IFS-2600 Block Diagram

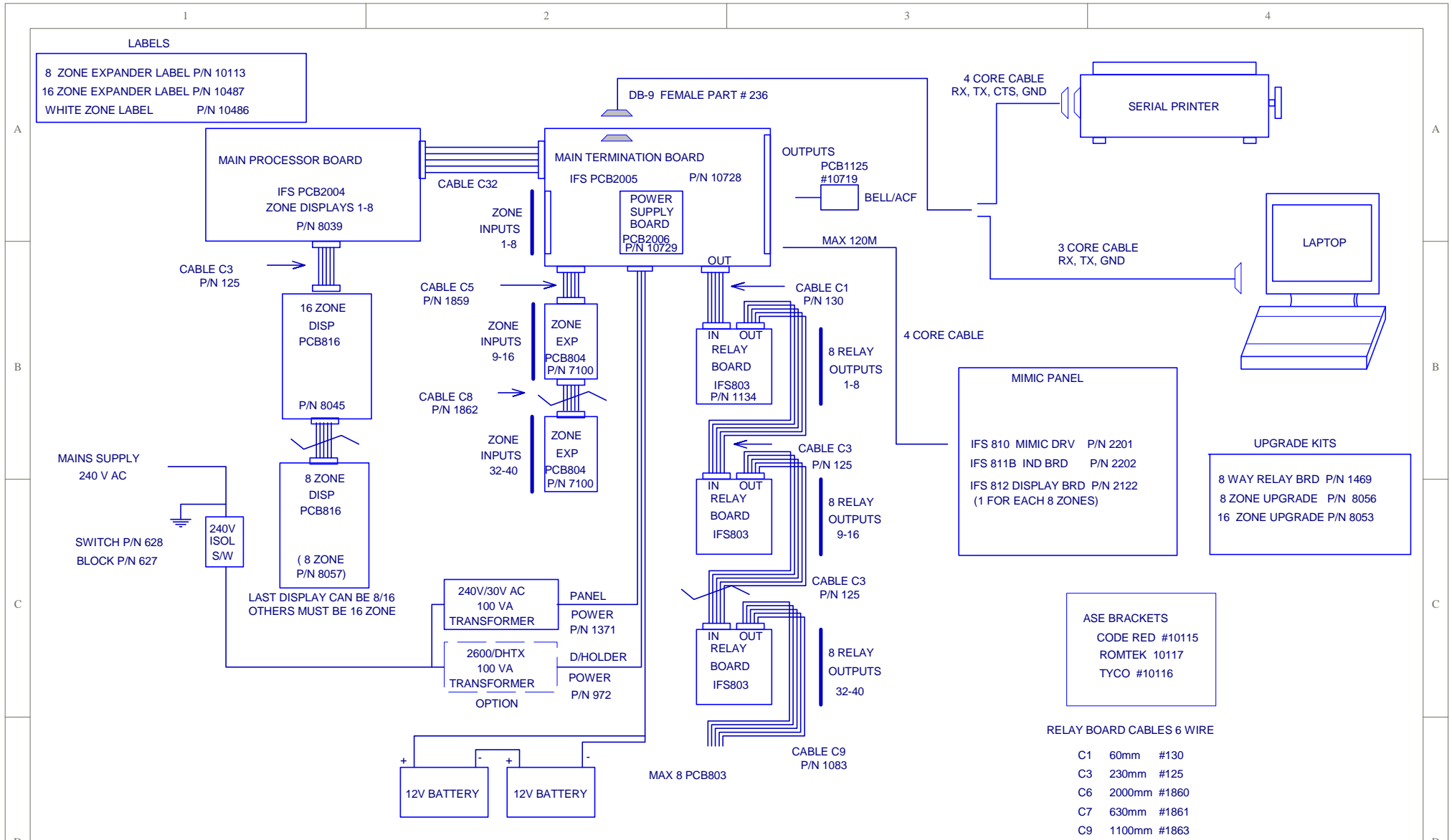

C	Revised Printer Connection	IP	IP	18/8/05
B	REVISED PART NUMBERS	G.W.	G.W.	9/3/04
NO.	Revision - revise on CAD. Do not amend by hand	Eng.	App.	Date

Copyright
This document is & shall remain the property of
Notifier Inertia Fire Systems ©
Unauthorized use of this document in any way is prohibited.
Drawing File No.
=DocumentFullPathAndName



7 Columbia Court,
Norwest Business Park
Baulkham Hills NSW 2153
AUSTRALIA
Tel 61 2 9894 1444
Fax 61 2 9899 4156
Email: support@inertia.com.au

Sheet: 1 Of: 1
Drawn/Traced 14/08/03
Engineer Design I.P.
Approved
This Drawing must not be used for Construction unless signed as approved

Title		Size	Drg. No.	Rev
IFS2600 BLOCK CONNECTION DIAGRAM				
A4		L2600-1	C	



New South Wales
(Head Office)
7 Columbia Court
Baulkham Hills NSW 2153

ph +61 (0)2 9899-4155
fax +61 (0)2 9899-4156

Queensland
24 Potts Street
East Brisbane, QLD 4169

ph +61 (0)7 3391 5777
fax +61 (0)7 3391 5800

Victoria
32 Lambert Street
Richmond, VIC 3121

ph +61 (0)3 9421 5552
fax +61 (0)3 9421 5553

Western Australia
Unit 4, 283 Camboon Road
Malaga WA 6090

ph +61 (0)8 9270 6555
fax +61 (0)8 9270 6556

New Zealand
264 Mt Eden Road
Auckland

ph +64 (0)9 623 5275
fax +64 (0)9 623 5060