



# **EXTINGUISHING AGENT RELEASE MODULE**

## **OPERATION, INSTALLATION & PROGRAMMING MANUAL**

5/10/2010 Rev: 3.03

DOC-01-005 ECN10-179

## Documentation Feedback

Your feedback helps us keep our documentation up to date and accurate. If you have any comments or suggestions about our printed manuals you can email us.

Please include the following information:

- Product name and version number (if applicable)
- Manual part number and revision (found on the front cover)
- Page number
- Brief description of the content you think should be improved or corrected
- Your suggestion for how to correct/improve documentation

Send email messages to:

**techpubs@notifier.com.au**

Please note this email address is for documentation feedback only. If you have any technical issues, please contact your nearest branch for technical support.



# **WARNING**

**DISCONNECT THE GAS  
HEAD BEFORE POWERING  
UP OR PERFORMING ANY  
MAINTENANCE ON THIS  
SYSTEM**

# Installation Precautions

*Adherence to the following will aid in problem-free installation with long-term reliability:*

**WARNING - Several different sources of power can be connected to the fire alarm control panel.**

Disconnect all sources of power before servicing. Control unit and associated equipment may be damaged by removing and/or inserting cards, modules, or interconnecting cables while the unit is energized. Do not attempt to install, service, or operate this unit until manuals are read and understood.

**Verify that wire sizes are adequate** for all initiating and indicating device loops. Most devices cannot tolerate more than a 10% voltage drop from the specified device voltage.

**Like all solid state electronic devices**, this system may operate erratically or can be damaged when subjected to lightning induced transients. Although no system is completely immune from lightning transients and interference, proper grounding will reduce susceptibility. Overhead or outside aerial wiring is not recommended, due to an increased susceptibility to nearby lightning strikes. Consult with the Technical Services Department if any problems are anticipated or encountered.

**Disconnect AC power and batteries** prior to removing or inserting circuit boards. Failure to do so can damage circuits.

**Remove all electronic assemblies** prior to any drilling, filing, reaming, or punching of the enclosure. When possible, make all cable entries from the sides or rear. Before making modifications, verify that they will not interfere with battery, transformer, or printed circuit board location.

**Do not over tighten screw terminals.** Over tightening may damage threads, resulting in reduced terminal contact pressure and difficulty with screw terminal removal.

**This system contains static-sensitive components.** Always ground yourself with a proper wrist strap before handling any circuits so that static charges are removed from the body. Use static suppressive packaging to protect electronic assemblies removed from the unit.

**Follow the instructions in the installation, operating, and programming manuals.** These instructions must be followed to avoid damage to the control panel and associated equipment. FACP operation and reliability depend upon proper installation.

**This equipment must be correctly programmed and installed to suit the specific application.** Please ensure correct operational parameters are set prior to commissioning. If further details on programming options are required, please consult the programming manual or contact our helpful technical support personnel.

## EMC WARNING:

This equipment may radiate radio frequency energy. It may also be affected by radio frequency energy and, if not installed and operated in accordance with the manufacturers instructions, may cause interference to radio communications. It has been tested and found to comply with the Class A radiated and conducted EMI requirements of AS/NZ 3548:1995 (including Amendments 1 & 2) as well as the EMI susceptibility requirements of applicable standards

Radio communication devices should not be used in the vicinity of fire panels or associated ancillary devices and systems.

# Table of Contents

<b>Section 1 About this Manual</b> .....	<b>4</b>
1.1. Notes, Cautions and Warnings.....	4
1.2. Related Documentation.....	4
<b>Section 2 System Overview</b> .....	<b>5</b>
2.1. Introduction.....	5
2.2. Features.....	5
2.3. Specifications.....	5
2.4. System Diagram.....	6
2.5. Available Kits.....	7
<b>Section 3 Installation</b> .....	<b>8</b>
3.1. Module Mounting.....	8
3.2. Inputs from CIE.....	10
a. Alarm Risk Inputs from CIE.....	10
b. Fault/Isolate Output from CIE.....	11
3.3. Inputs circuits.....	11
a. Lock off Valve and Pressure Switch.....	11
b. Local Control Station (LCS).....	12
3.4. Output circuits.....	13
a. Relay Outputs.....	13
b. ACF Output.....	13
c. Warning Sign Outputs.....	14
3.5. Extinguishing agent releasing device (Gas head).....	15
<b>Section 4 Operation</b> .....	<b>16</b>
4.1. Display module controls.....	16
4.2. Display module indicators.....	16
4.3. Normal Operation.....	17
4.4. Fault Operation.....	17
4.5. Isolate/De-Isolate Operation.....	18
a. Service Isolate.....	18
b. Automatic Discharge Inhibit.....	18
c. Lock off Valve Input.....	19
4.6. Alarm Operation.....	19
a. Manual activation.....	19
b. Automatic Activation by CIE.....	19
4.7. Extinguishing Agent Release Event.....	20
4.8. Discharge input from pressure switch.....	20
<b>Section 5 Configuration</b> .....	<b>21</b>
5.1. Releasing delay timer.....	21
5.2. Initiate/Discharge relay output (SW1).....	21
5.3. Manual Discharge release delay (SW3).....	21
5.4. Latching/Non-Latching Alarm outputs (SW4).....	22
<b>Section 6 Local Control Station (LCS)</b> .....	<b>23</b>
6.1. Specifications.....	23
6.2. Mounting.....	23
6.3. Wiring.....	24
<b>Section 7 Warning Signs</b> .....	<b>25</b>
7.1. Introduction.....	25
7.2. Features.....	25

7.3.	Specifications .....	25
7.4.	Installation.....	25
a.	<i>Synchronizing multiple signs</i> .....	26
b.	<i>External Sounders</i> .....	26
c.	<i>Mute Switch</i> .....	26
7.5.	Mounting.....	26
7.6.	Wiring .....	28
7.7.	Configuration .....	29
a.	<i>Single / Dual Level (JP1)</i> .....	29
b.	<i>Continuous / Flashing (JP2)</i> .....	29
c.	<i>Enable Sounder (JP3)</i> .....	29
d.	<i>Enable Buzzer (JP4)</i> .....	29
e.	<i>Disable External Mute (JP5)</i> .....	29
<b>Section 8 Pyrozone Interface.....</b>		<b>30</b>
8.1.	Specification .....	30
8.2.	Mounting.....	30
8.3.	Wiring .....	30
8.4.	Configuration .....	30
<b>Section 9 Diagnostics .....</b>		<b>31</b>
9.1.	Frequently Asked Questions .....	31
a.	<i>How do I clear a fault on the front panel</i> .....	31
b.	<i>How do to isolate the risk area for temporary construction work in the risk ....</i>	31
c.	<i>How do I stop the device firing accidentally during maintenance?</i> .....	31
d.	<i>Can I get the Gas Card to Mute the System Inoperative Signs?</i> .....	31
e.	<i>How do I test the System?</i> .....	31

# Section 1 About this Manual

## 1.1. Notes, Cautions and Warnings

This manual contains notes, cautions and warnings to alert the reader as follows:



**NOTE:** Supplement information for a topic such as tips and references.



**CAUTION:** Information about procedures that could cause programming errors, runtime errors, or equipment damage.



**WARNING:** Indicates information about procedures that could cause irreversible equipment damage, irreversible loss of programming data or personal injury.

## 1.2. Related Documentation

Title	Document Number
Local Control Station (LCS) – Installation Sheet	DOC-03-005
Warning Sign – Installation & Configuration Sheet	DOC-03-006

**Table 1-1 Related Documentation**

# Section 2 System Overview

## 2.1. Introduction

The Notifier extinguishing agent release control module is used to control the release of fire extinguishing agents in accordance with AS4214.

## 2.2. Features

- Dual risk operation – from three risk inputs
- Designed for agent release standard AS4214
- Field devices
  - ✓ Local Control Station (LCS)
  - ✓ Extensive range of warning signs
- Adjustable discharge delay timer
- Output contacts for
  - ✓ Alarm 1 & Alarm 2
  - ✓ System Fault
  - ✓ Automatic/Manual operation
  - ✓ Discharge
- High power 5A Extinguishing Agent release device output
- Optional Pyrozone interface

## 2.3. Specifications

- Operating Voltage Range: 18VDC to 28VDC
- Current Consumption @ 24VDC nominal
  - ✓ Normal/Quiescent: 35mA
  - ✓ Alarm: 59mA (Level 1) 138mA (Level 2)

*Current consumption values do not include load devices such as warning signs and solenoids*
- For use indoors in a dry location
- Form-C Relay Outputs
  - ✓ Discharged
  - ✓ 1<sup>st</sup> Alarm
  - ✓ 2<sup>nd</sup> Alarm
  - ✓ System Fault – Normally Energised
  - ✓ Automatic / Manual Operation
  - ✓ Relay Contact Ratings: 1A @ 30VDC (resistive)
- Warning Sign Outputs
  - ✓ Single Level Warning Sign (DNE) – with Fuse F3
  - ✓ Dual Level Warning Sign (W/SIGN) – with Fuse F1
  - ✓ System Inoperative (INOPR) – with Fuse F4
  - ✓ Output Ratings: 1A @ 24VDC nominal
  - ✓ End-of-Line-Resistor: IFS-1125 or 4.7K Ohm ¼ Watt
- ACF Output
  - ✓ Output Rating: 1A@ 24VDC nominal – with Fuse F2
  - ✓ End-of-Line-Resistor: 4.7K Ohm ¼ Watt
- Extinguishing Agent Release Device (Gas Head)
  - ✓ Output Rating: 5A @ 24VDC nominal – with Fuse F6
  - ✓ End-of-Line-Device: IFS-1125 or 4.7K Ohm ¼ Watt
- Monitored Inputs
  - ✓ Risk 1, Risk 2 and Risk 3
  - ✓ CIE Fault (FLT)
  - ✓ End-of-Line-Resistor: 4.7K Ohm ¼ Watt
- Pyrozone Interface – (on control module - not functioning)
  - ✓ Start & Stop
  - ✓ End-of-Line-Resistor: 1.0K Ohm ¼ Watt

## 2.4. System Diagram

A block diagram of a typical extinguishing agent release is provided in Figure 2.1

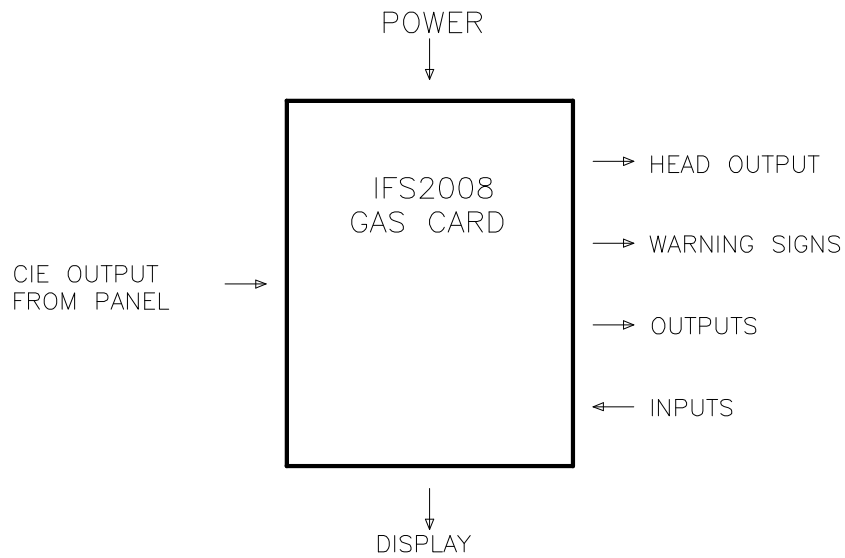

Figure 2.1 - Typical extinguishing agent release system layout

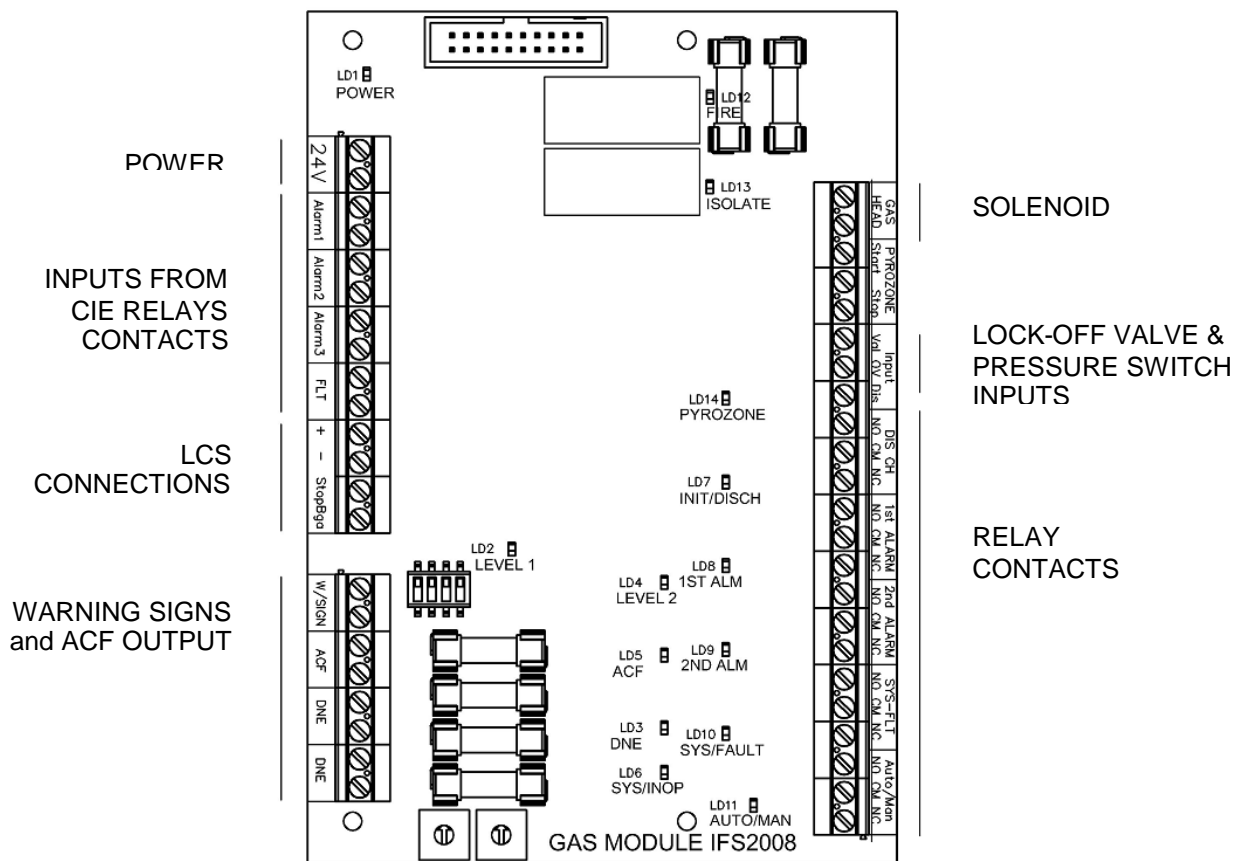

Figure 2.2 – Typical extinguishing agent release module connections

## 2.5. Available Kits

The following kits are available from Notifier:

Title	Notifier Part #
Extinguishing agent Release Module – includes control and display modules and 2 x IFS-1125 end of line devices	ASY-02-001
Replacement extinguishing agent release control module	ASY-02-002
Local Control Station (LCS)	FG-42-001
Warning signs – Indoor and Outdoor Varieties	* see note below
Pyrozone Interface	PCA-01-012

**Table 2-1 Available Kits**

\* For part numbers of warning signs please see your Notifier systems consultant.

## Section 3 Installation



**WARNING:** Remove all power sources to equipment while connecting electrical components. Leave the external, main power breaker OFF until installation of the entire system is complete.

### 3.1. Module Mounting

Complete the following steps to install the extinguishing agent release control board:

1. Mount the control module board onto a standard relay expansion slot using 4 off M3 x 8mm screws as shown in Figure 3.1

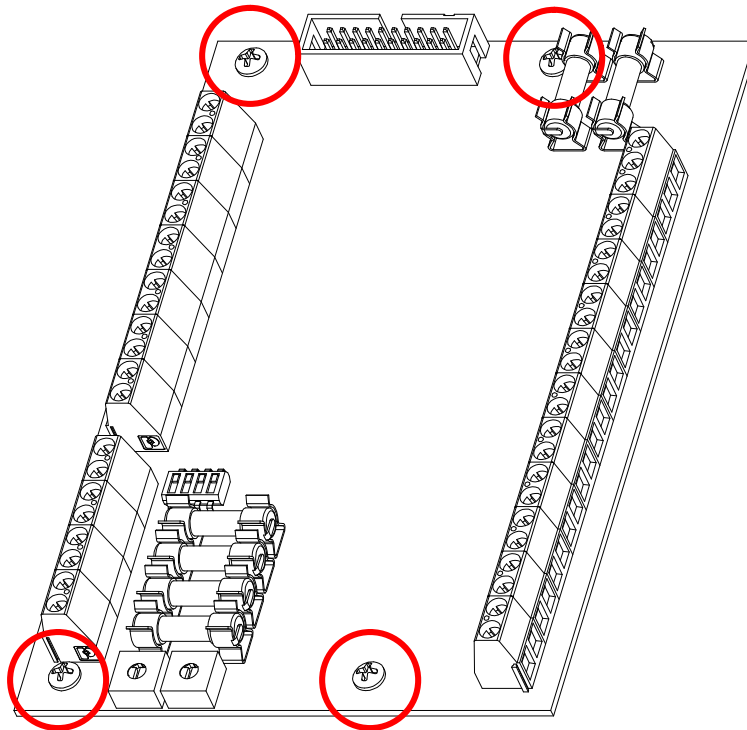
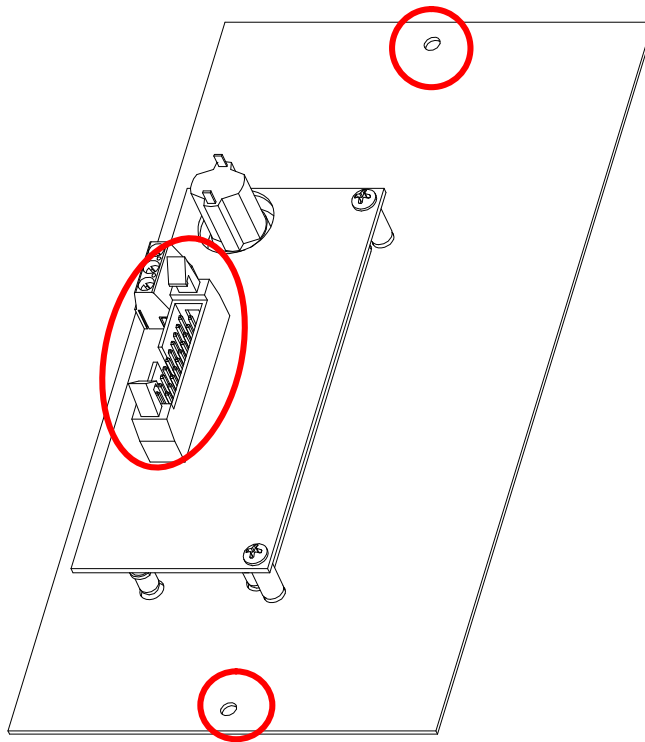

Figure 3.1 - Extinguishing agent release control module mounting

2. Remove annunciator blank plate and mount display module using 2 x M3 flanged nuts by the 2 mounting points as shown in Figure 3.2



**Figure 3.2 - Extinguishing agent release Display module mounting and ribbon cable connection**

3. Connect display module to control module using provided 20 way ribbon cable as shown in Figure 3.2 and Figure 3.3.

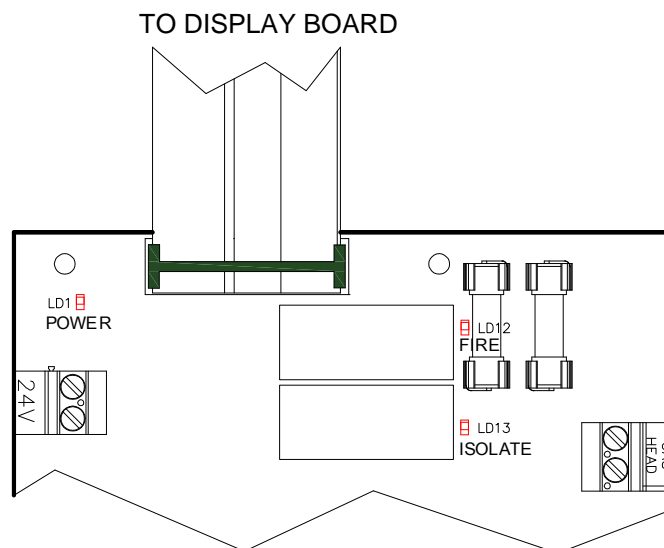

**Figure 3.3 - Connecting display module to control module**

4. Connect 24V battery backed power to the controller module. A diagram of the controller module is shown in Figure 3.2. The source for the 24V battery-backed power supply is dependant on CIE type and configuration, standard configurations are shown in section
5. Connect inputs from CIE for risks 1 to 3 and fault/isolate. See Sections 3.2.a and 0
6. Connect inputs from system Lock-off Valve and Pressure Switch. See Section 3.3.a
7. Connect outputs to external equipment. See Sections 3.4.a and 3.4.b
8. Connect Local Control Station (LCS). See Section 3.3.b and Section 6
9. Connect Warning Sign/s. See Section 3.4.c and Section 7
10. When the hardware installation is complete, configure operation as per Section 5
11. Connect extinguishing agent release device (gas head/solenoid). See Section 3.5

## 3.2. Inputs from CIE

### a. Alarm Risk Inputs from CIE

Connect inputs Risk 1 to 3, to normally open alarm relay contacts of the CIE. Inputs are monitored by the control module via 4k7 End-Of-Line resistors. See Figure 3.4

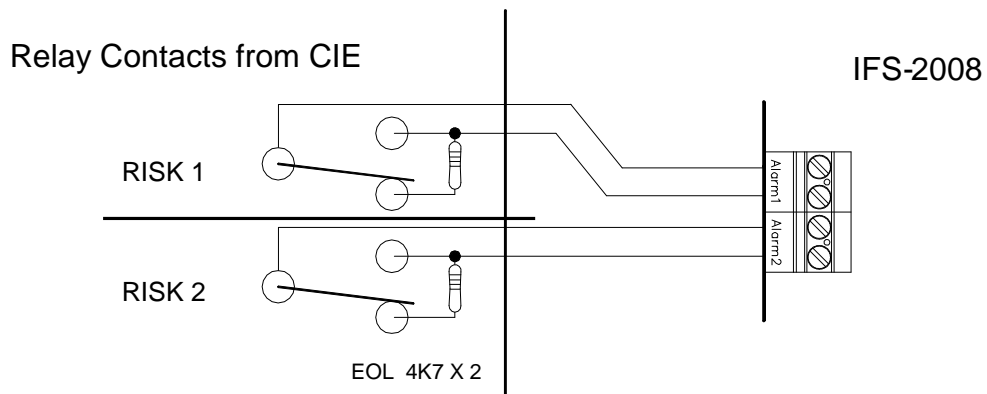

**Figure 3.4– Alarm Risk Inputs**



**NOTE:** The relay contacts should be programmed as general alarm from Risk 1 and Risk 2 respectively

**b. Fault/Isolate Output from CIE**

Connect the Gas Card Fault/Isolate input to a normally open relay contact. The output from the CIE should be programmed to activate during a system fault or isolate.

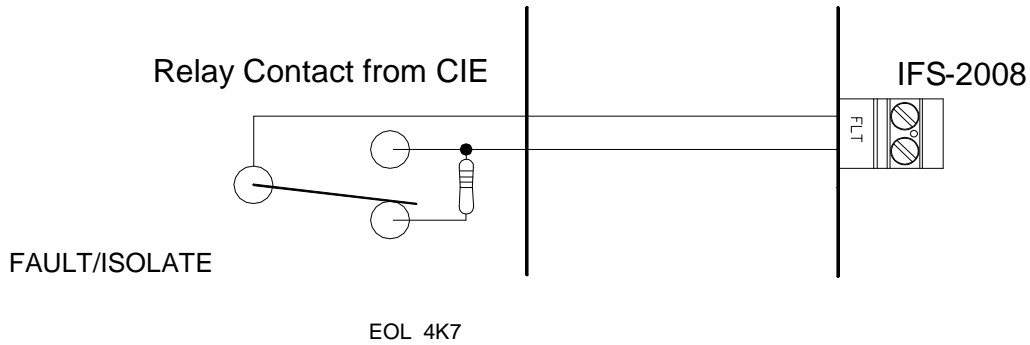

**Figure 3.5 – Fault/Isolate connection to IFS-2008**



**NOTE:** The relay contact should be programmed to change over if any part of the risk is isolated or in fault

**3.3. Inputs circuits**

**a. Lock off Valve and Pressure Switch**

Connect the extinguishing agent Lock off Valve and Pressure switch to the inputs as shown below;

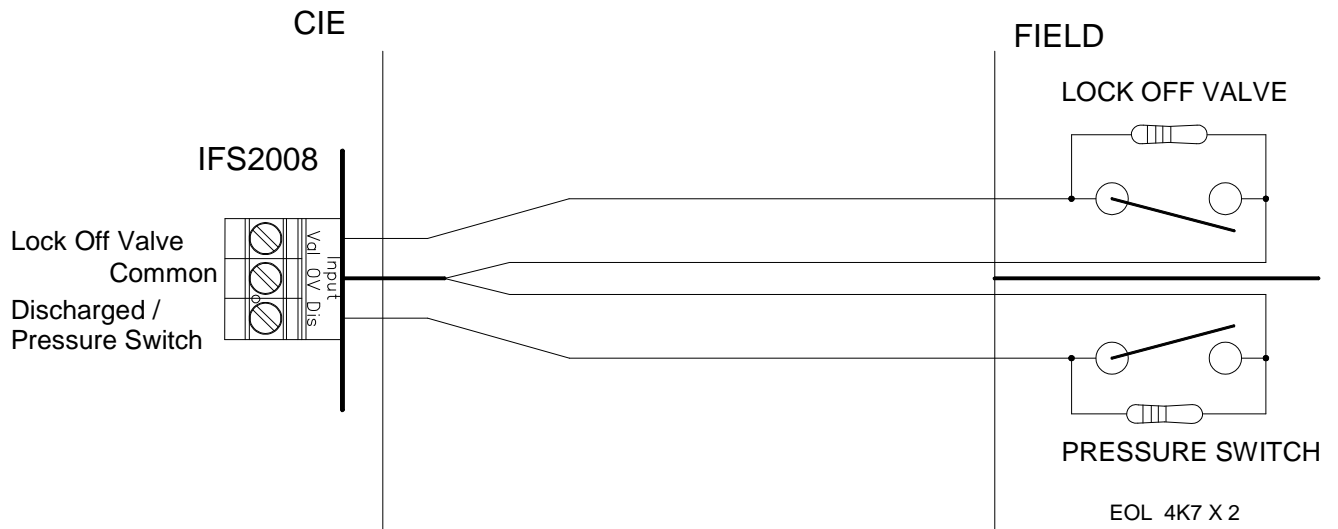

**Figure 3.6 – Lock Off Valve and Pressure Switch Connection to IFS-2008**

### b. Local Control Station (LCS)

Connect the LCS to the inputs as shown in Figure 3.7

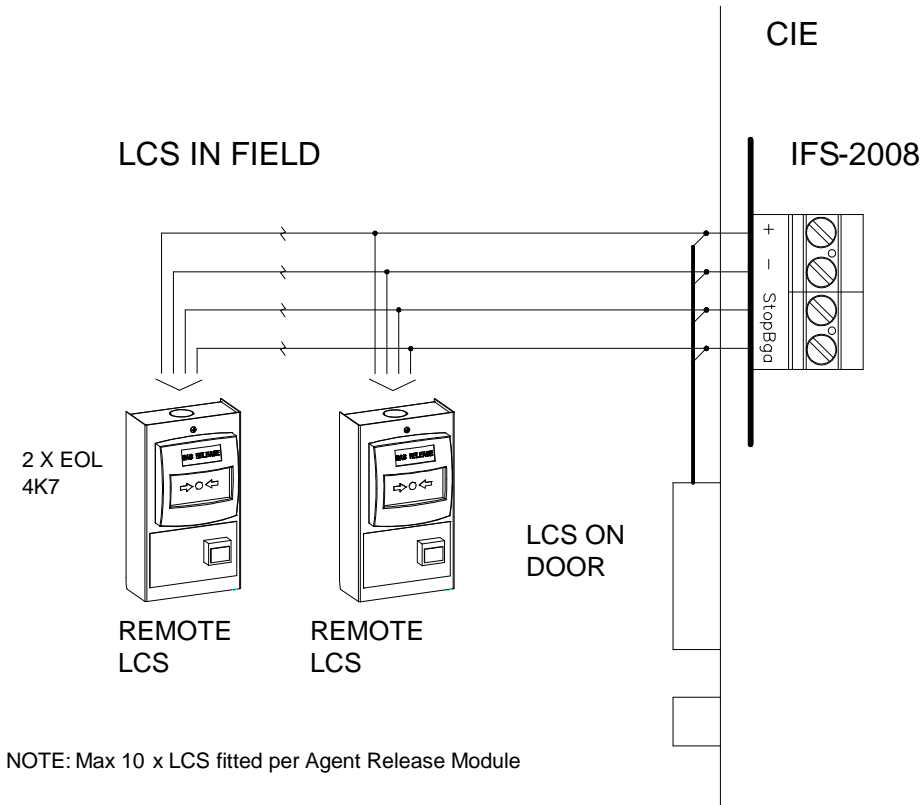

Figure 3.7 – LCS connection to IFS-2008



**CAUTION:** Only the last LCS unit from the IFS-2008 should have EOL resistors fitted to the stop and release connection otherwise accidental discharge may result.



**NOTE:** See Figure 6.2 for internal LCS connection

### 3.4. Output circuits

#### a. Relay Outputs

Connect the relay contacts to external device inputs to provide signal of gas initiated or gas discharged. The For configuration of this output see Section

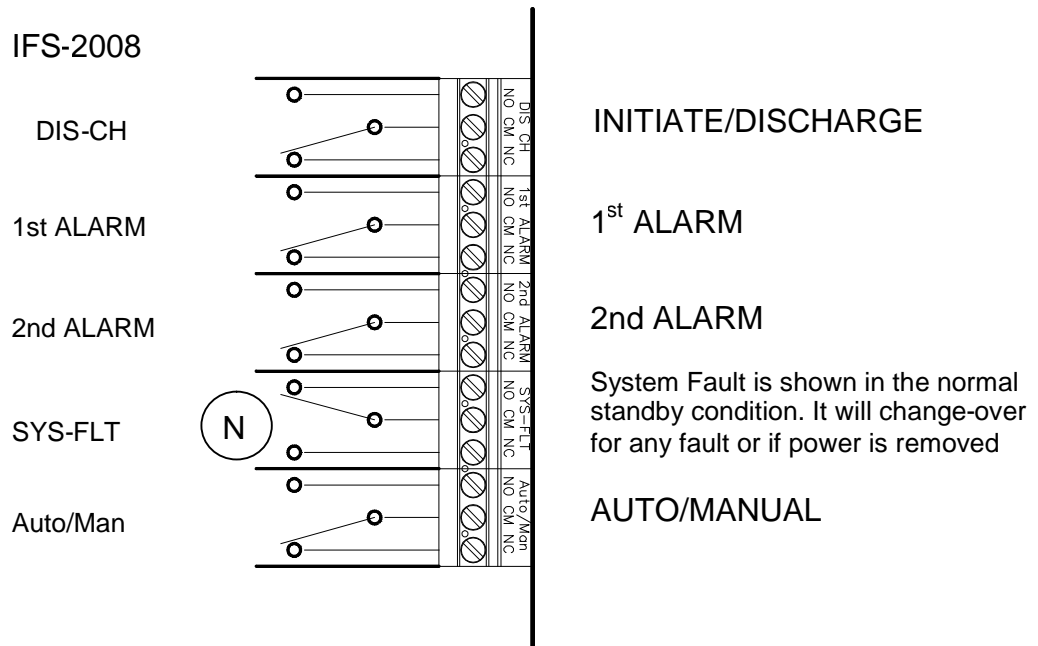

Figure 3.8 – Relay outputs

#### b. ACF Output

Connect the monitored powered output to external equipment, usually air-conditioning shutdown relays as shown below.

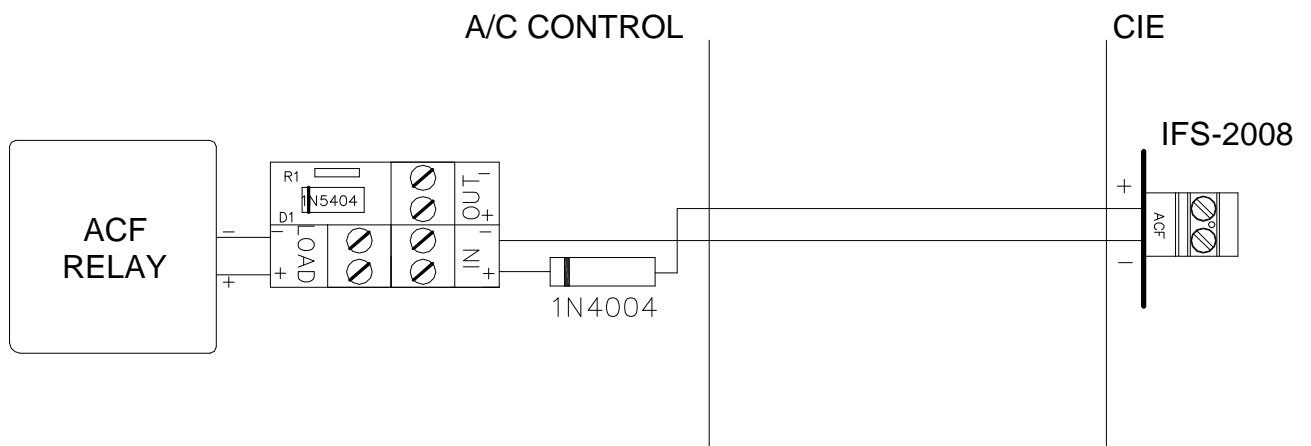

Figure 3.9 - ACF output connection



**NOTE:** 4.7K Ohm end-of line resistor is fitted to IFS-1125 and a separate resistor is not required

### c. Warning Sign Outputs

Connect warning signs to required warning sign outputs (W/Sign, DNE, INOPR) of the agent release control module as shown in Figure 3.10

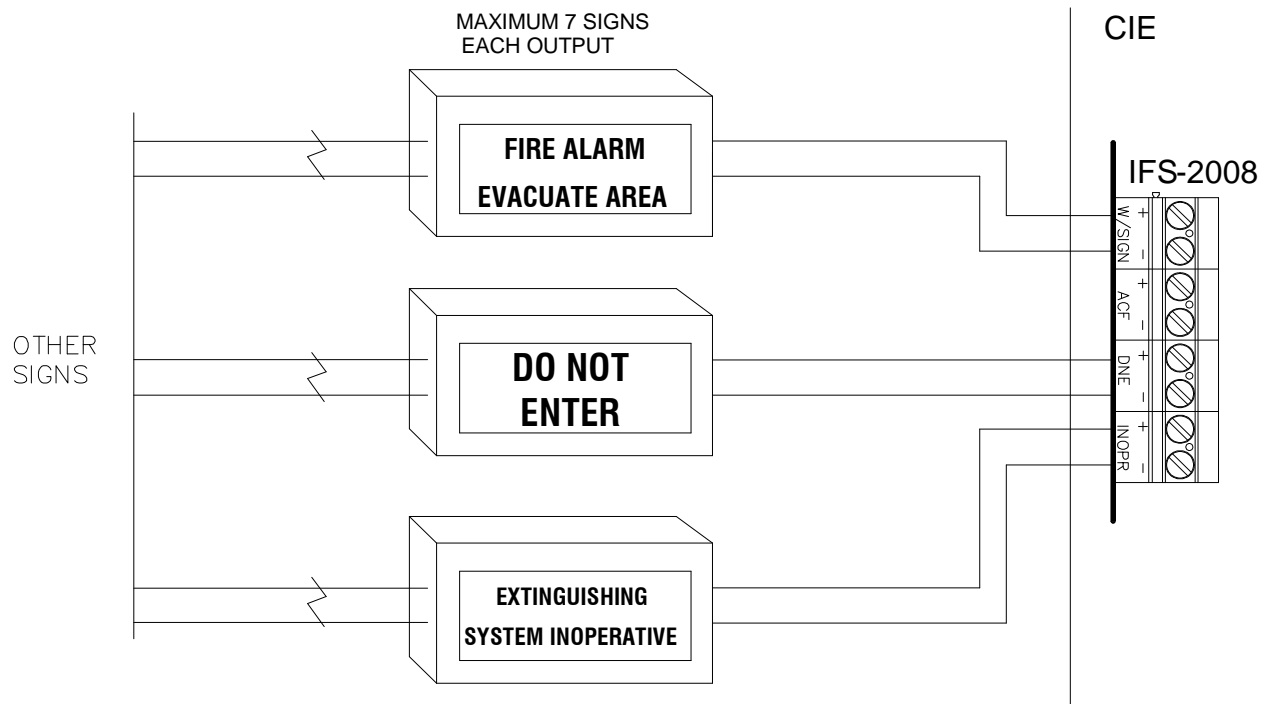

NOTE: Max 7x Warning Signs per Agent Release Module output

Figure 3.10 – Typical Warning Sign Connections



**NOTE:** See Figure 7.5 for internal Warning Sign connection and warning sign interconnection.

### 3.5. Extinguishing agent releasing device (Gas head)

The extinguishing agent release device (gas head) output is a monitored output providing 24Vdc to the releasing device.

1. Mount IFS-1125 as close as possible to releasing device.
2. Connect IFS-2008 (gas head output) to *IN* of IFS-1125 as shown in Figure 3.11.
3. Connect extinguishing agent release device (gas head or solenoid) to *LOAD* of IFS-1125 as shown in Figure 3.11.

#### CIE PANEL

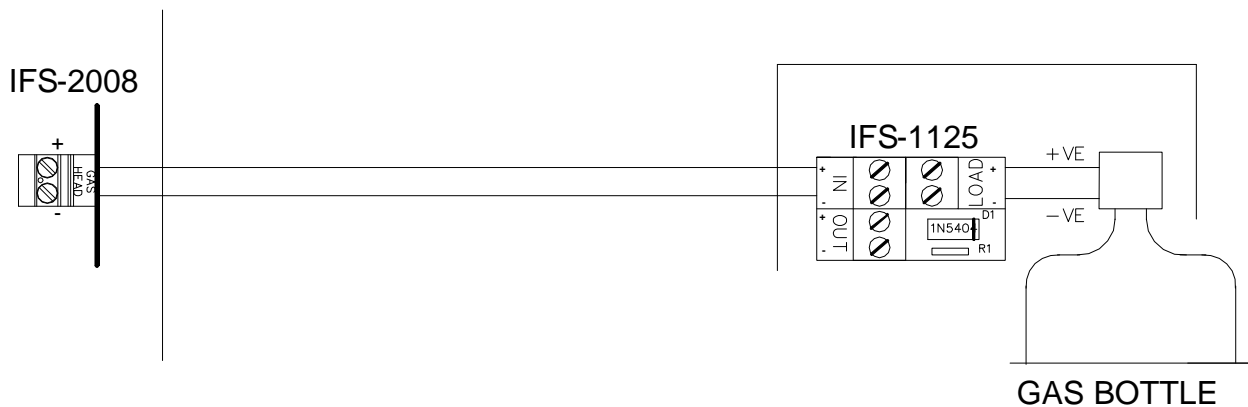

**Figure 3.11 - Extinguishing agent release device (Gas head) connection**



**NOTE:** 4.7K Ohm end-of line resistor is fitted to IFS-1125 and a separate resistor is not required. To ensure correct monitoring it is important that the IFS-1125 is placed within the enclosure for the extinguishing agent release device.

# Section 4 Operation

## 4.1. Display module controls

There are two control on the display module. One orange illuminated latching switch labelled (*Service Isolate*) and one black momentary button labelled (*Reset / Lamp Test*). Their function is as follows;

### Service Isolate

This orange illuminated switch will activate and deactivate the Service Isolate function (see Section 4.5a).

### Reset / Lamp test

If there are no latched alarm events the black button momentary switch will perform a lamp test on all indicators on the display module.

If the system has been configured for latching Level 2 alarms (see Section 5.4) and a Level 2 alarm is currently latched (*System Latched* indicator is illuminated) momentarily pressing will reset all outputs and indications.

## 4.2. Display module indicators

The fifteen indicators, which are located on the extinguishing agent release display module operate as follows;

### System Normal

This is a green indicator which illuminates if power is applied to the extinguishing agent release module and there are no faults, isolates or alarms on the system.

### Level 1

This red indicator illuminates when the system is Level 1 or higher alarm which occurs when;

1. one or more risk inputs have been activated by the CIE
2. manual activation by a break glass alarm of a Local Control Station (LCS).

It turns off when all alarms have cleared.

### Level 2

This red indicator illuminates when the system is Level 2 alarm which occurs when;

- two or more risk inputs have been activated by the CIE
- manual activation by a break glass alarm of a Local Control Station (LCS).

It turns off when all alarms have cleared or the system returns to Level 1.

### Timer Running

This red indicator flashes to indicate a releasing event has been initiated and the releasing delay timer has been started. It will turn off when either the Level 2 alarm is cleared or *Service Isolate* is activated

### Suppression Initiated

This red indicator illuminates when the extinguishing agent release circuit has activated and a discharge is taking place.

### Suppression Discharged

This blue indicator illuminates when the *Gas Discharged* input is activated from system pressure switch. It turns off when the input is removed.

### Manual Release Activated

This red indicator illuminates when a manual break glass alarm is activated on a Local Control Station (LCS) which can be located in the field or on the CIE outer door.

### Auto Operation Disabled

This is a yellow indicator that illuminates when an automatic discharge is disabled by

pressing the *Service Isolate* button on the display module or the *Automatic Activation Isolate* button on an LCS

#### **LCS Fault**

This yellow indicator illuminates when an open circuit wiring fault exists on a Local Control Station (LCS). It will turn off when the fault is cleared.

#### **Suppression Fault**

This yellow indicator illuminates when an open circuit wiring fault is present on the *Lock off Valve* or *Gas Discharged* (Pressure Switch) or when an open circuit or short circuit wiring fault exists on the *Extinguishing agent release* (Gas Head) or the in-built *Pyrozone* interface.

#### **CIE Fault**

This yellow indicator illuminates when a fault indication (open-circuit) is provided by the CIE to the *Fault* input of the control module. It will also illuminate if any of the *Risk* inputs from the CIE are open or short circuit.

#### **Sign Fault**

This is a yellow indicator which illuminates when an open or short circuit wiring fault exists on any of the warning sign outputs (*W/Sign*, *DNE*, *Inopr*)

#### **ACF Fault**

This is a yellow indicator which illuminates when an open or short circuit wiring fault exists on the *ACF* output.

#### **System Latched**

This is a red indicator which illuminates when a Level 2 alarm has been latched. It can be reset by momentarily pressing the Reset button of the display module.

### **4.3. Normal Operation**

With no faults or isolations on the system the *SYSTEM NORMAL* indicator will be illuminated with all other indicators off.

### **4.4. Fault Operation**

A fault on the system will cause the following;

- One or more fault indications to illuminate on the display module to identify the source of the fault(s).
- The Fault (*SYS-FLT*) relay output to de-activate.
- The System Inoperative (*INOPR*) sign output to activate.



**NOTE:** The source of the fault is indicated on the display module i.e. Sign fault, CIE Fault, ACF Fault or Suppression Fault.

If all faults are cleared and there are no isolates, the system returns to normal mode operation and the *System Normal* indicator illuminates. Fault conditions are also displayed during alarm operation.



**NOTE:** The Fault (*SYS-FLT*) output relay is normally energized and will drop out during a fault condition. See Figure 3.8

## 4.5. Isolate/De-Isolate Operation

### a. Service Isolate

The activation of the Service Isolate switch on the display module will cause the following;

- *Auto Operation Isolated* indicator on the display module will illuminate.
- *System Normal* indicator on the display will turn off
- *Suppression Fault* indicator on the display will illuminate
- The System Fault (*SYS-FLT*) output on the control module will de-activate.
- System Inoperative (*INOPR*) sign output will activate.
- Automatic / Manual (*Auto/Man*) output will activate.
- The internal lamp of the Automatic Discharge Inhibit (*Gas Isolate*) switch will illuminate on all Local Control Stations (LCS).
- The internal buzzer will sound on all Local Control Stations (LCS).
- The extinguishing agent (*Gas Head*) output is electrically isolated.
- If a release event is occurring, the *Suppression Isolated* indicator on the display module will illuminate and the extinguishing agent (*Gas Head*) output will be isolated

The de-activation of the Service Isolate switch on the display module will cause the following;

- If there is an alarm event (*Level 1, Level 2 or Manual Release*) present the release sequence will re-start. i.e. if the alarm is configured to have a release delay timer then the delay time will re-start.
- Other indicators and outputs will return to normal operation.

### b. Automatic Discharge Inhibit

The activation of a the *Automatic Discharge Inhibit (Gas Isolate)* switch on a Local Control Station (LCS) will cause the following;

- *Auto Operation Isolated* indicator on the display module will illuminate.
- *System Normal* indicator on the display will turn off.
- System Inoperative (*INOPR*) sign output will activate.
- System Fault (*SYS-FLT*) output on the control module will de-activate.
- Automatic / Manual (*Auto/Man*) output will activate.
- The internal lamp of the Automatic Discharge Inhibit (*Gas Isolate*) switch on all Local Control Stations (LCS) will illuminate.
- The internal buzzer will sound on all Local Control Stations (LCS).
- The system will be prevented from automatically discharging due to activation of the risk inputs.



**CAUTION:** *The Automatic Discharge Inhibit (Gas Isolate) switch of a Local Control Station (LCS) will not prevent a manual discharge from a Break Glass Alarm input. It will also not de-activate the extinguishing agent release (Gas Head) output once a release has been initiated.*



**NOTE:** A Local Control Station (LCS) may be fitted to the outer door of the CIE and has the same function as an LCS installed in the field.

### c. Lock off Valve Input

The activation of the *Lock-off Valve* input on control module will cause the following;

- *Auto Operation Isolated* indicator on the display module will illuminate.
- *System Normal* indicator on the display will turn off
- *Suppression Fault* indicator on the display will illuminate
- The System Fault (*SYS-FLT*) output on the control module will de-activate.
- System Inoperative (*INOPR*) sign output will activate.
- Automatic / Manual (*Auto/Man*) output will activate.
- The internal lamp of the Automatic Discharge Inhibit (*Gas Isolate*) switch will illuminate on all Local Control Stations (LCS).
- The internal buzzer will sound on all Local Control Stations (LCS).
- The extinguishing agent (*Gas Head*) output is electrically isolated.
- If a release event is occurring, the *Suppression Isolated* indicator on the display module will illuminate and the extinguishing agent release (*Gas Head*) output will be de-activated.

The de-activation of the Lock off Valve on the display module will cause the following;

- If there is an alarm event (*Level 1, Level 2* or *Manual Release*) present the release sequence will re-start. I.e. if the alarm is configured to have a release delay timer then the delay time will re-start.
- Other indicators and outputs will return to normal operation.

## 4.6. Alarm Operation

### a. Manual activation

The activation of an alarm event by a Break Glass Alarm (BGA) on a Local Control Station (LCS) will cause the following;

- *Level 1 & Level 2* indicator on the display module will illuminate.
- *Manual Release Activated* indicator on the display will illuminate.
- The *Alarm 1 & Alarm 2* outputs on the control module will activate.
- Warning Sign (*W/SIGN*) output will activate in “Level 2 mode”. See Section 7
- Do Not Enter (*DNE*) sign output will activate.
- *ACF* output will activate.
- If a releasing delay timer has been configured for manual activation (See Sections 5.1 and 5.3) then releasing delay timer will begin, causing the *Timer Running* indicator on the display module to flash.

Once the releasing delay timer has expired or if manual activation is configured not to have a releasing delay time, an extinguishing agent release event will occur. (See Section 4.7)

### b. Automatic Activation by CIE

The activation of a single risk input will cause the following;

- *Level 1* indicator on the display module will illuminate.
- *Alarm 1* output on the control module will activate.
- Warning Sign (*W/SIGN*) output will activate in “Level 1 mode”. See Section 7

The activation of two or more risk inputs will cause the following;

- *Level 1* indicator on the display module will illuminate.
- *Level 2* indicator on the display module will illuminate.
- *Alarm 1* output on the control module will activate
- *Alarm 2* output on the control module will activate.
- Warning Sign (*W/SIGN*) output will activate in “Level 2 mode”. See Section 7
- Do Not Enter (*DNE*) sign output will activate.
- *ACF* output will activate.
- The releasing delay timer will begin causing the *Timer Running* indicator on the display module to flash (this will not occur if releasing delay time = 0 sec).

Once releasing delay timer has expired an extinguishing agent release event will occur. (See Section 4.7)

## 4.7. Extinguishing Agent Release Event

An extinguishing release will cause the following

- *Timer 1 Running* indicator will turn-off if timer has just expired.
- Extinguishing agent release (*Gas Head*) output will activate.
- *Suppression Initiated* indicator will illuminate
- Initiate / Discharge (*DIS-CH*) output will activate (only if configured to activate on initiating release see Section 0)
- The *System Latched* indicator on the display module will illuminate (only if system is configured to have latching Level 2 Alarms see Section 5.4)

If the system has been configured for latching Level 2 Alarms (see Section 5.4) all warning sign (DNE and W/SIGN) and ACF outputs will remain active until the system is reset

## 4.8. Discharge input from pressure switch

Activation of the discharge input from a system pressure switch is used to confirm activation of the system and will cause the following;

- *Suppression Discharged* indicator will illuminate.
- Warning Sign (*W/SIGN*) output will activate in “Level 2 mode”. See Section 7
- Do Not Enter (*DNE*) sign output will activate.
- *ACF* output will activate.
- The Initiate / Discharge (*DIS-CH*) output will activate (only if configured to activate on discharge signal see Section 5.2)

# Section 5 Configuration

## 5.1. Releasing delay timer

The releasing delay timer determines the length of time (in seconds) that an alarm will be present before an extinguishing agent discharge event occurs. The factory default setting is 30 seconds with selectable range from 0 seconds (no delay) to 990 seconds (16 mins 30secs) in increments of 10 seconds.

The releasing delay timer is set using two decade rotary switches on the control module as shown in Figure 5.1. The left switch sets seconds (x100) and the right switch set seconds (x10).

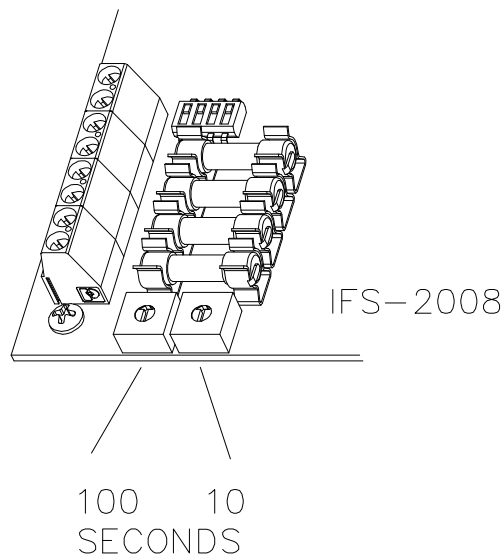

Figure 5.1 – Releasing Delay Timer Configuration

## 5.2. Initiate/Discharge relay output (SW1)

The operation of the Initiate/Discharge (*DIS-CH*) output is determined by the position of SW1 on the 4-way DIP switches on the control board as pictured in Figure 5.2

<b>SW1:</b>	<b>ON:</b>	Initiate/Discharge ( <i>DIS-CH</i> ) output is activated when a discharge event is initiated.
	<b>OFF:</b>	Initiate/Discharge ( <i>DIS-CH</i> ) output is activated when pressure switch (DIS) input is active.

Table 5-1 - SW1 configuration

## 5.3. Manual Discharge release delay (SW3)

SW3 (shown in Figure 5.2) determines if the releasing delay time is applied to Break Glass Alarm (BGA) inputs from a Local Control Station (LCS)

<b>SW3:</b>	<b>ON:</b>	A Break Glass Alarm on an LCS will cause an instant extinguishing agent release event.
	<b>OFF:</b>	A Break Glass Alarm on an LCS will cause a delay extinguishing agent release event. The delay time is the same as the automatic alarm releasing delay time (see Section 5.1)

Table 5-2 - SW3 configuration

### 5.4. Latching/Non-Latching Alarm outputs (SW4)

SW4 (shown in Figure 5.2) determines if warning sign (*DNE* and *W/SIGN*) and *ACF* outputs will remain active until the system is reset (see Section 4.1).

<b>SW4:</b>	<b>ON:</b>	Warning sign ( <i>DNE</i> and <i>W/SIGN</i> ) and <i>ACF</i> outputs are latched until <i>Reset</i> is pressed.
	<b>OFF:</b>	Warning sign ( <i>DNE</i> and <i>W/SIGN</i> ) and <i>ACF</i> outputs Non-Latching and are reset when the alarm is cleared.

**Table 5-3 - SW4 configuration**



**NOTE:** SW2 is not used

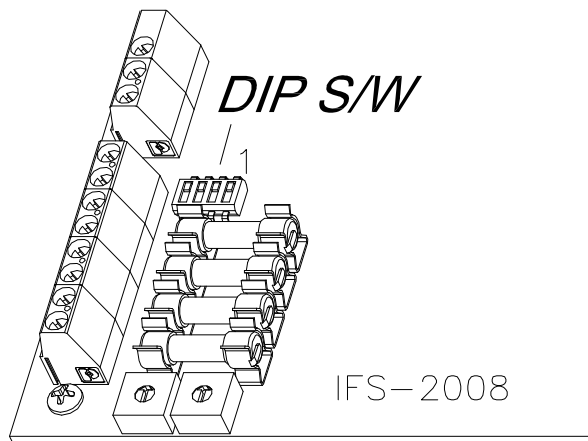

**Figure 5.2 – DIP Switch Configuration**

# Section 6 Local Control Station (LCS)

## 6.1. Specifications

- Operating Voltage Range: 18VDC to 28VDC
- Current Consumption @ 24VDC nominal
  - ✓ Normal/Quiescent: 0mA
  - ✓ Alarm: 0mA
  - ✓ Automatic Discharge Inhibited: 68mA
- For use indoors in a dry location
- Overall Dimensions
  - ✓ Width: 115mm
  - ✓ Height: 200mm
  - ✓ Depth: 80mm
  - ✓
- Max number of LCS to 1x Agent Release module: 10

## 6.2. Mounting

1. Remove retaining screw for the LCS lid allowing it to be lifted out of the work area
2. Mount the base of the LCS on the wall using the mounting holes shown in Figure 6.1
3. Replace lid onto base and re-fit retaining screw

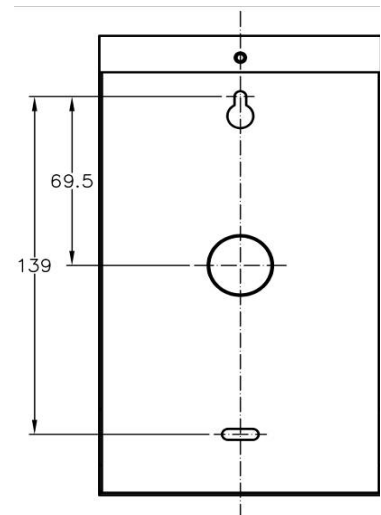

Figure 6.1 – LCS Mounting Positions

### 6.3. Wiring

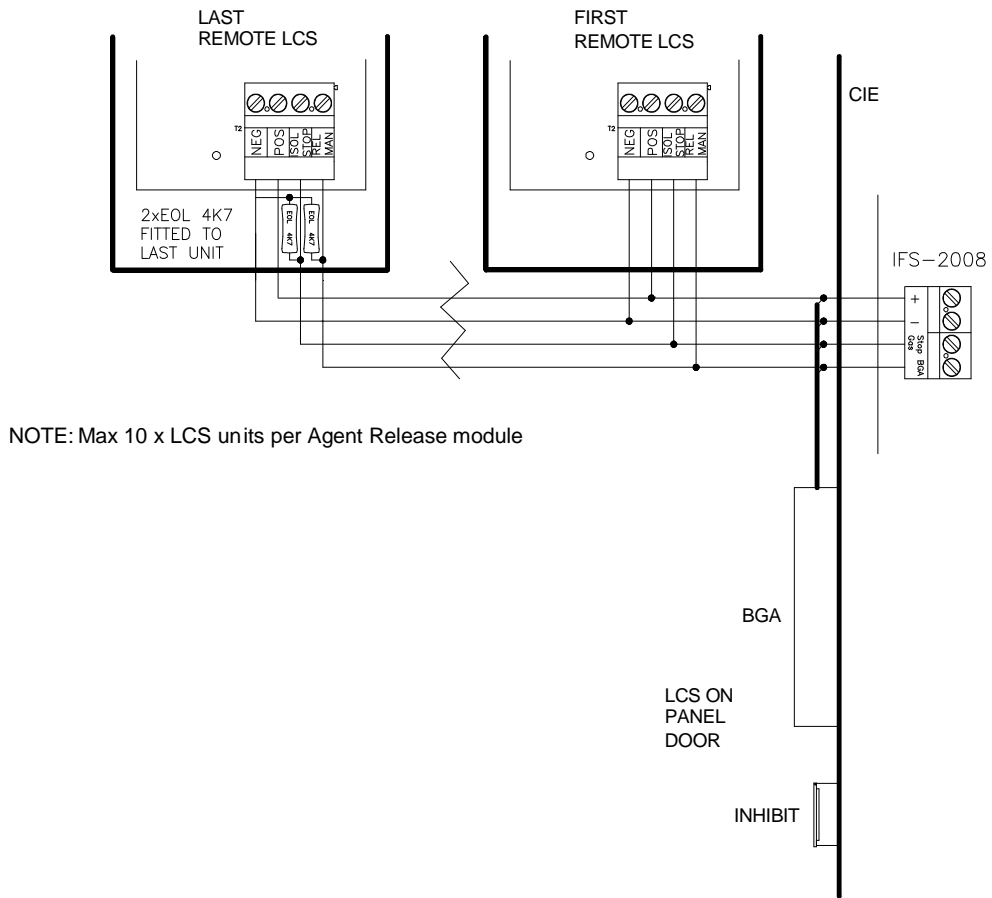

Figure 6.2 – Internal LCS connection

# Section 7 Warning Signs

## 7.1. Introduction

The Notifier Warning Signs are designed to provide occupants of an area a visual warning alerting them to a potentially dangerous situation. When used in conjunction with the extinguishing agent release module the warning sign becomes a component of an AS4214 extinguishing agent release system.

## 7.2. Features

- Configurable single or dual level operation
- External sounder output
- Internal sounder output
- Mute input for internal and external sounder
- Ability to synchronize flash rate with other signs in accordance with AS1603.11
- Amber and Red colour options

## 7.3. Specifications

- Operating Voltage Range: 18VDC to 28VDC
- Current Consumption @ 24VDC nominal
  - ✓ Normal/Quiescent: 0.1mA
  - ✓ Alarm Level 1: 85mA (65mA with internal sounder muted)
  - ✓ Alarm Level 2: 135mA (110mA with internal sounder muted)
- IP Rating
  - ✓ Indoor: IP40
  - ✓ Outdoor: IP65
- Overall Dimensions (Indoor)
  - ✓ Width: 315mm
  - ✓ Height: 190mm
  - ✓ Depth: 73mm
- Overall Dimensions (Outdoor)
  - ✓ Width: 294mm
  - ✓ Height: 198mm
  - ✓ Depth: 63mm
- Maximum number of warning signs per output: 7

## 7.4. Installation

1. Remove power from the panel.
2. Set the jumpers on the warning sign as required. Refer to Section 7.7 for jumper configuration.
3. Mount the warning sign as shown in Figure 7.1 to Figure 7.4
4. Connect the wiring connections of the sign as per Section 7.6
5. Mount required warning sign fascia with the warning sign enclosure and secure with the provided screws. For the outdoor version, insert the gasket before mounting the fascia to the enclosure.

**a. Synchronizing multiple signs**

In accordance with AS1603.11 it is possible to synchronize the flash rates of warning signs. To achieve this connect SYNC + and SYNC – of all required signs together as shown in Figure 7.5.



**NOTE:** It is possible to synchronize the flash rate of warning signs that are driven from different outputs of the same agent release module but not warning signs powered from separate modules

**b. External Sounders**

Connect required sounder either (2-wire or 3-wire) to the corresponding terminals of the adjacent warning sign as shown in Figure 7.5 . The external sounder outputs will be energised to Tone 1 when the sign is in Level 1 alarm and Tone 2 when the sign is in Level 2 alarm



**NOTE:** If the *Mute* input is shorted via a momentary switch, the internal sounder and external sounder outputs (if configured see section 7.7.e) will be silenced. The sounders will re-sound when the sign is re-energised

**c. Mute Switch**

Connect a momentary switch to the Mute input terminals as shown in Figure 7.5

**7.5. Mounting**

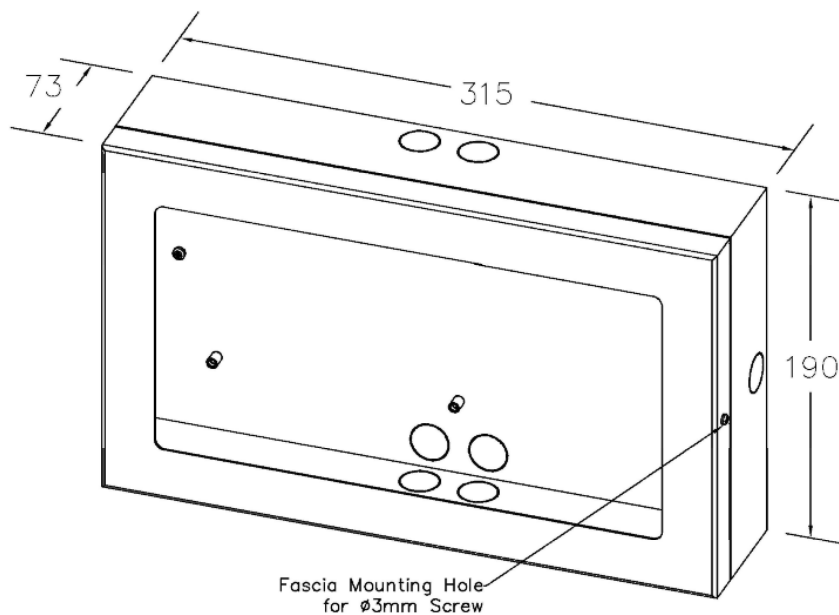

**Figure 7.1 – Warning Sign (Indoor version) Fascia mounting detail**

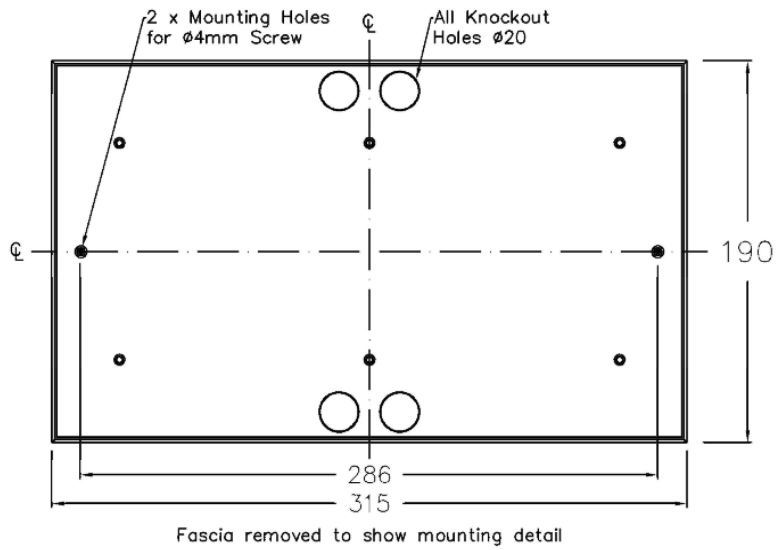

Figure 7.2– Warning Sign (Indoor version) mounting detail

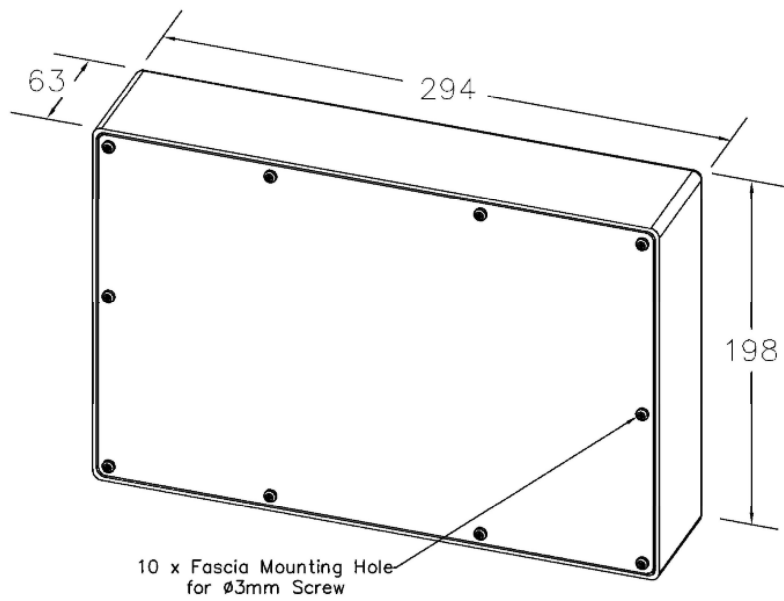

Figure 7.3– Warning Sign (Outdoor version) Fascia mounting detail

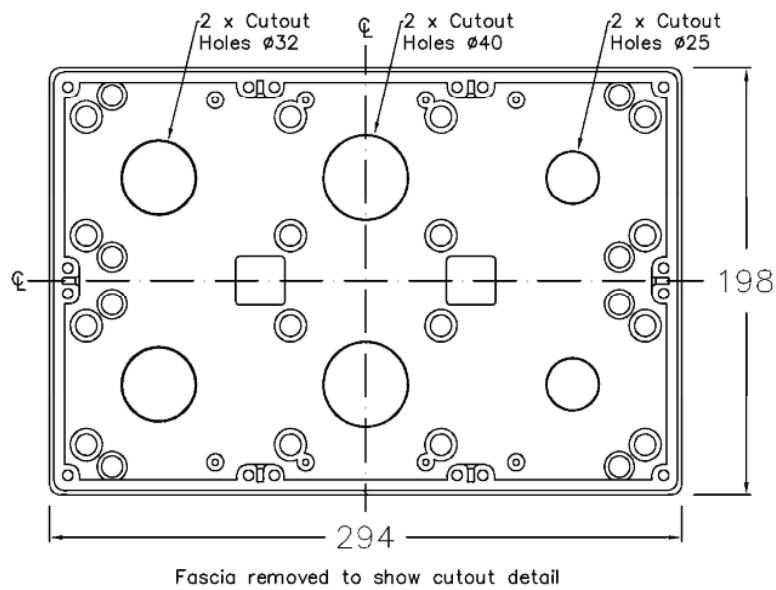

Figure 7.4 – Warning Sign (Outdoor version) mounting and cutout detail

### 7.6. Wiring

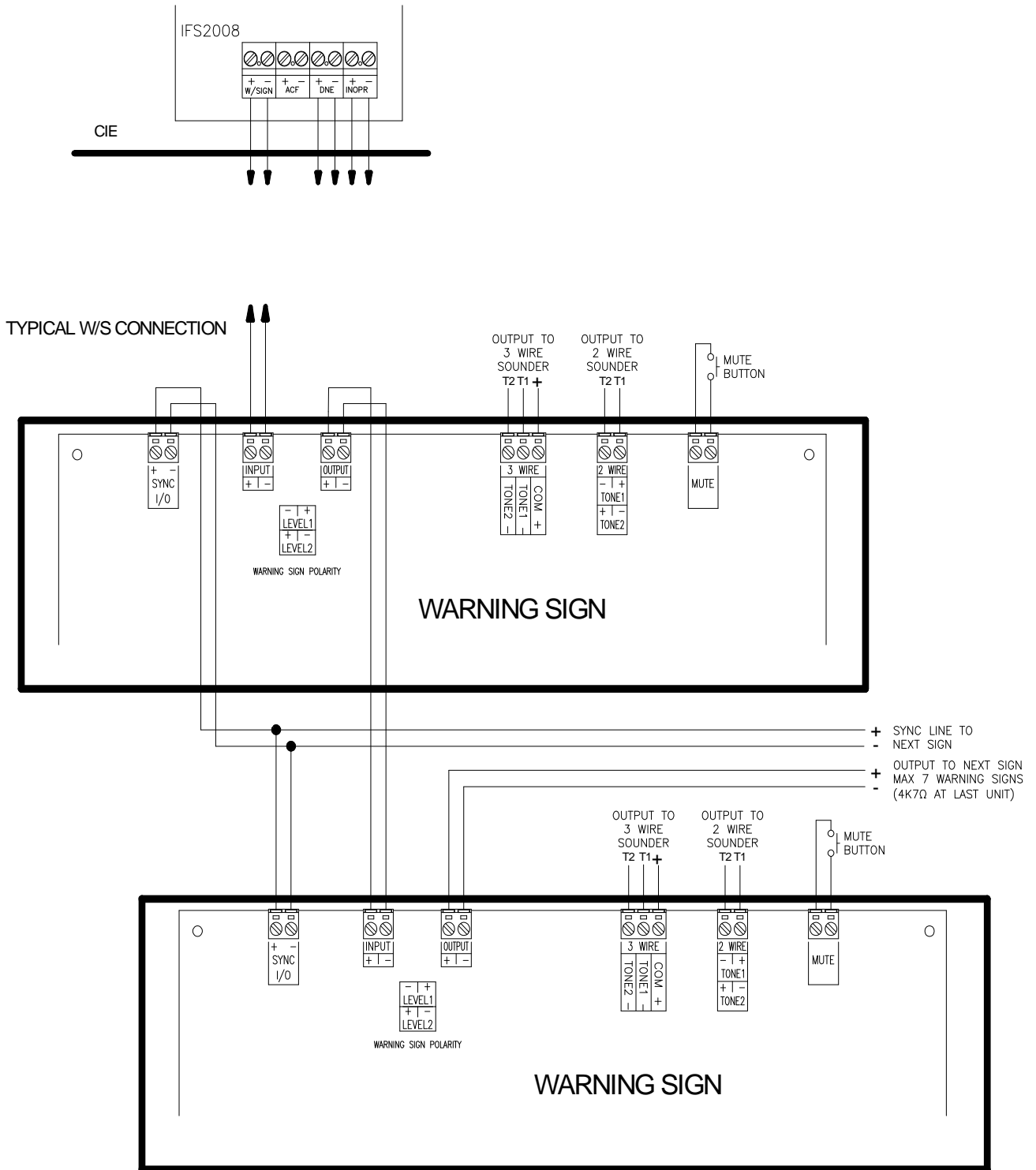

Figure 7.5 – Typical Warning Sign Connection

## 7.7. Configuration

### a. Single / Dual Level (JP1)

Configuration of JP2 determines whether the internal buzzer and LEDs are flashing or continuous as per below table.

<b>JP1:</b>	<b>Fitted on links 1-2:</b>	DUAL LEVEL – Top Row LEDs will be on at Level 1 Alarm  All LEDs will be on at Level 2 Alarm
	<b>Fitted on links 2-3:</b>	SINGLE LEVEL – All LEDs will be on at Level 1 & Level 2 Alarm

**Table 7-1 – JP1 configuration**

### b. Continuous / Flashing (JP2)

Configuration of JP2 determines whether the internal buzzer and LEDs are flashing or continuous as per below table.

<b>JP2:</b>	<b>Fitted on links 1-2:</b>	CONTINUOUS – LEDs steady on with alarm activation  Internal buzzer outputs continuous warning tone
	<b>Fitted on links 2-3:</b>	FLASHING – LEDs flash at approximately 2.3Hz  Internal buzzer outputs beeping warning tone

**Table 7-2 – JP2 configuration**

### c. Enable Sounder (JP3)

Configuration of JP3 determines whether the external sounder output is enabled as per below table. T

<b>JP3:</b>	<b>Fitted:</b>	External sounder output is ENABLED
	<b>Non-Fitted:</b>	External sounder output is DISABLED

**Table 7-3 - JP3 configuration**

### d. Enable Buzzer (JP4)

Configuration of JP4 determines whether the internal sounder is enabled as per below table.

<b>JP4:</b>	<b>Fitted:</b>	Internal buzzer is ENABLED
	<b>Non-Fitted:</b>	Internal buzzer is DISABLED

**Table 7-4 – JP4 configuration**

### e. Disable External Mute (JP5)

Configuration of JP5 determines whether the external buzzer mute input is enabled as per below table.

<b>JP5:</b>	<b>Fitted:</b>	External buzzer mute input is DISABLED
	<b>Non-Fitted:</b>	External buzzer mute input is ENABLED

**Table 7-5 – JP5 configuration**

# Section 8 Pyrozone Interface

## 8.1. Specification

- Operating Voltage Range: 18VDC to 28VDC
- Current Consumption @ 24VDC nominal
  - ✓ Normal/Quiescent: 36mA
  - ✓ Alarm: 87mA
- For use indoors in a dry location

## 8.2. Mounting

1. Mount the Pyrozone interface module adjacent to the agent release control module using the 4 holes in the PCB via adhesive stand-offs or provided mounting points
2. Mount the timer module base adjacent to the Pyrozone release module on a short length of DIN rail. Firmly press the timer module into its base.

## 8.3. Wiring

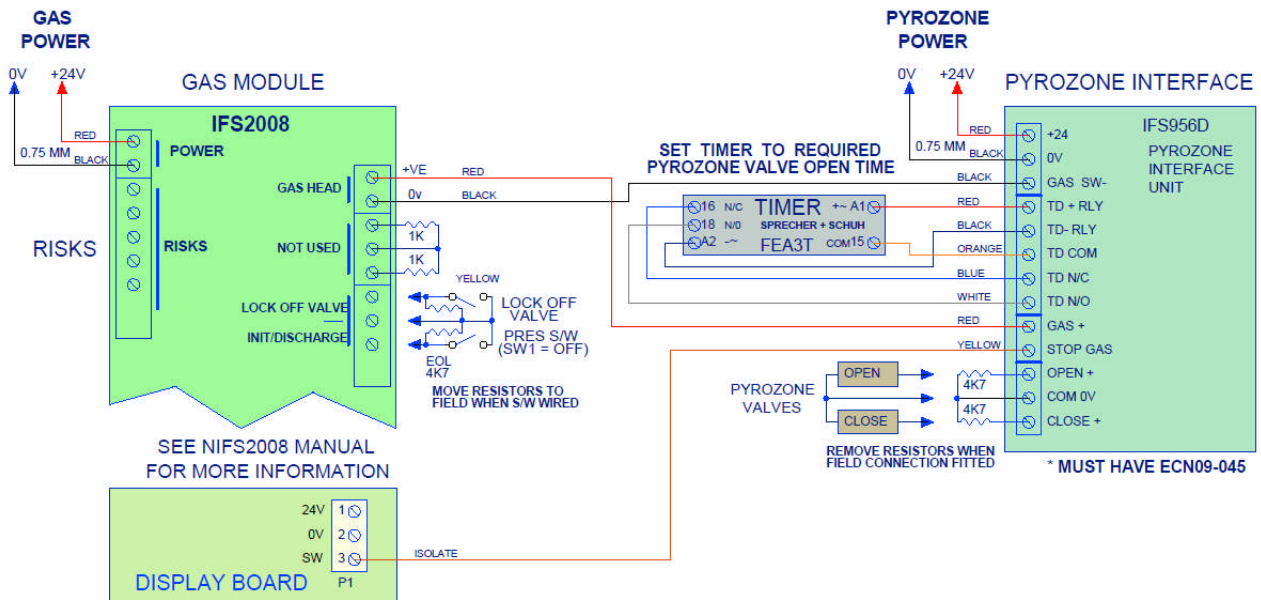

Figure 8.1- Pyrozone connection

## 8.4. Configuration

Set to timer module for the required time that the extinguishing open valve is held open.

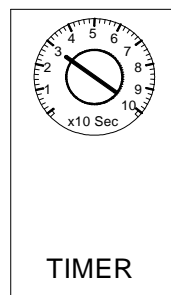

Figure 8.2- Pyrozone timer configuration

# Section 9 Diagnostics

## 9.1. Frequently Asked Questions

### a. How do I clear a fault on the front panel

- Determine the cause of the fault :
- LCS Fault, EOL O/C on Stop or BGA, on the last LCS.
- Suppression Fault, EOL O/C on gas head, (Pyrozone on card uses 2 x 1K EOL), Lock off
  - Valve or Pressure switch use 4k7.
- CIE Fault, EOL O/C on risks 1-3, FLT input and Gas discharged input.
- Sign Fault, EOL on each warning sign output.
- ACF Fault, EOL O/C or PCB1125B with additional diode not fitted.
- Clear the cause of the fault and fit the required EOL resistor.

### b. How do to isolate the risk area for temporary construction work in the risk

- Inhibit the automatic discharge, by activating the Isolate on the LCS (manual mode).
- This will not allow the risk to activate the system automatically, but it can be discharged manually with the BGA, if a fire in the risk needs to be suppressed.
- The System Inoperative sign/s will flash and beep but the beep can be muted by fitting a mute Push Button on the side of each sign.
- The LCS will also beep but this cannot be muted.

### c. How do I stop the device firing accidentally during maintenance?

- Activate the Maintenance Isolate switch inside the locked door to totally isolate the system.



**NOTE:** for extra total isolation, the agent release activation device (gas head) should be removed from the bottle

### d. Can I get the Gas Card to Mute the System Inoperative Signs?

- The warning signs have a function to mute the internal buzzer.
- When the sign is active, a n/o push button on the side of the sign will mute the buzzer after it has been activated.

### e. How do I test the System?

- Notify the Building Manager or Owner and any monitoring authority, that testing is to be undertaken.
- Isolate the gas head mechanically from the bottle.
- The ACF should also be isolated.
- Test the system as per AS1851 Table 11.4.1.

# Notes

# Notes



New South Wales  
(Head Office)  
9 Columbia Way  
Baulkham Hills NSW 2153

ph +61 (0)2 9899-4155  
fax +61 (0)2 9899-4156

Western Australia  
Unit 4, 283 Camboon Road  
Malaga WA 6090

ph +61 (0)8 9270 6555  
fax +61 (0)8 9270 6556

Queensland  
24 Potts Street  
East Brisbane, QLD 4169

ph +61 (0)7 3391 5777  
fax +61 (0)7 3391 5800

New Zealand  
264 Mt Eden Road  
Auckland

ph +64 (0)9 623 5050  
fax +64 (0)9 623 5060

Victoria  
32 Lambert Street  
Richmond, VIC 3121

ph +61 (0)3 9421 5552  
fax +61 (0)3 9421 5553